

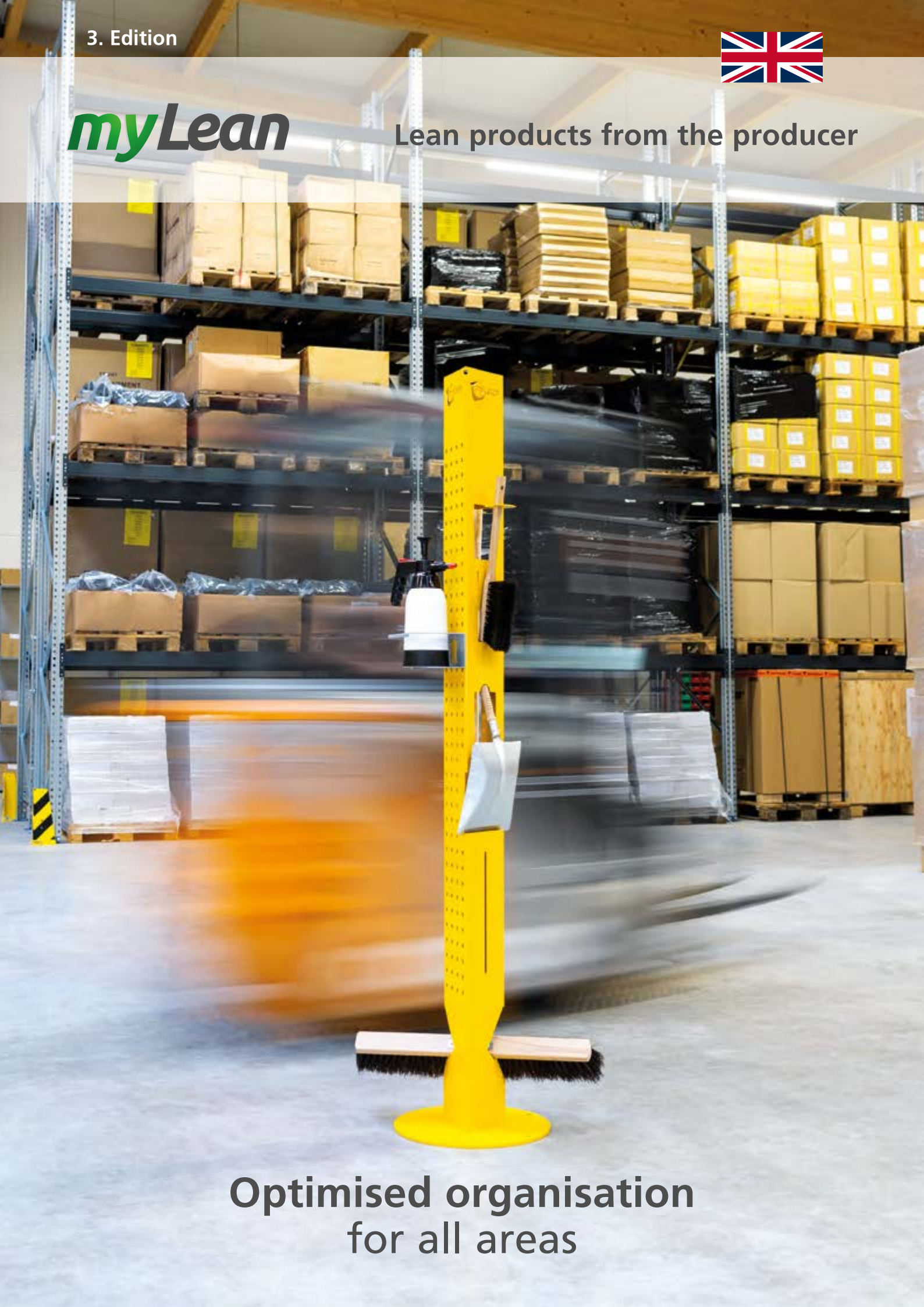

myLean

Lean products from the producer



**Optimised organisation
for all areas**



Index

- 04 Company**
- 06 Shadowboards | Shadow adhesive | Services**
Individual shadowboard, 3D-Printed inlays, Process: scanning, Services: scanning, application examples, Accessories
- 20 5S Cleaning stations**
cleanTower, cleanTower Flexi, cleanTower Quick, First-AidTower, cleanTower Mobile, accessories, broom holder
- 38 Floor mats**
Customised configuration, ESD, Flow, Flat, Smooth, Luxury, Vario, Pearl, Harmony, Legend
- 56 Floor markings**
LongLife tape goods, LongLife tape goods: Hatched, LongLife tape goods: ESD, LongLife Floor strips, LongLife Crosswalk stripes, LongLife Symbols: Easy, LongLife Symbols: Signs, LongLife Clear window, LongLife Floor signs doorways, LongLife Cutting device, LongLife Cleaner, LongLife floor labeling signs, Services, myLinienlaser, mySpot LED-Projector, Service: myLean Floor markings
- 88 Signage**
General information, poster frames, pallet stand, accessories, list holder, custom business signage
- 102 Markings**
Attachable visible pockets, visible pockets with magnetic tape, visible pockets with neodymium magnet, KANBAN Visible pockets, general warehouse labelling, C-profiles, transparent magnetic labels, magnetic tape
- 118 Magnet- and whiteboards**
myLean magnet board customised, myLean whiteboard, myLean whiteboard customised, myLean LeanCube, accessories
- 136 Material flow**
Supply trolley, pallet trolley & pallet cover, FiFo-material supply, parking rails, ground roller: Dolly 64, crate lifters
- 148 Profile construction**
Customised profile solutions
- 153 Imprint**

www.my-Lean.com



Your specialist for lean products – Optimised organisation for all areas

As a specialist for lean products, myLean GmbH produces and sells products for lean production. The constantly growing product portfolio includes products for the entire value chain of a company. Thanks to the use of high-quality materials and certification in accordance with DIN EN ISO 9001: 2015 certification, international customers appreciate the quality of our goods. myLean products are used in many applications and different sectors. Thanks to a high level of vertical integration, extensive warehousing and streamlined processes, myLean products are delivered to you in the shortest time possible. With short response times and competitive prices, we help you to enjoy a tidy and clean workplace.

— Customised for your requirements

- 8 – 9 Your individual shadowboard
- 10 – 11 3D-Printed inlays
- 12 Process: scanning
- 13 Services: scanning
- 14 – 15 Application examples
- 16 – 18 Accessories

— Your individual shadowboard



We produce individual foam inserts for your equipment

There are no limits when it comes to developing and designing your individual shadowboard. No matter what your requirements are, myLean will produce the perfect shadowboard for you. myLean shadowboards are made of one- or two-coloured foams. The Two-colour system allows the user to immediately identify missing tools or workpieces. The myLean shadowboards comply with international lean standards. Thanks to the customised production method, shadowboards can be used for a wide variety of applications.

— Customised for your requirements



5S Method

S – Sort | S – Systematise | S – Set-Up
S – Standardise | S – Self-discipline

Simple handling with the Shadowboard-Creator

The simple and easy to understand Shadowboard-Creator helps you to design your foam inserts, hard plastic inserts, shadow adhesives or shadow magnets. The software is user-friendly and self-explanatory. We would be happy to support you in using our Shadowboard Creator.

Please note that the software is only designed for Windows only.



— Your individual options



Shadowboards made of foam



Hard plastic inlays

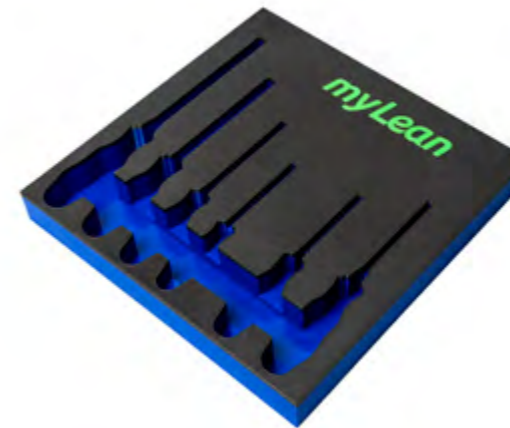

3D-Printed inlays (Filament print)



5S Shadow magnets & 5S Shadow glue

Simply put together your own customised shadowboard

myLean produces the foam inserts in
Colours: black, blue-black, green-black, red-black, yellow-black, grey-black and black-ESD
Heights: 30 mm, 60 mm und 90 mm
Other colours or insert heights on request.
^





Shadowboards from the 3D-printer – customize now!

Customize your shadowboards even more with the latest 3D-printing technology! Customize every detail - from the shape to the color - and create a clear and personalized storage solution that is perfectly adapted to your needs. Maximize efficiency and organization in your work environment!

Contact

Tel. 07024 466 27 0 | info@my-Lean.com



3D- printed inlays by contract manufacturing
We are also happy to manufacture individual 3D-printed parts according to your specifications!

Customized 3D-Printed inlays (filament print)

Our 3D-Printed inlays offer customized solutions with individual shapes, sizes and structures, perfectly tailored to your requirements. Thanks to the latest 3D-printing technology, you have almost unlimited design and color options. The precisely manufactured sleeves and recesses ensure optimal organization of your tools and accessories. High-quality materials also ensure robust and durable quality, ideal for intensive use.

- Size bis 650 x 650 x 350 mm (L,W,H)
- Material: PETG (other plastics on request)
- Individual adaptability
- Wide range of colors
- Durability and robustness
- ESD material possible
- Weight saving due to honeycomb structure
- Cost-efficient

Simply put together your individual 3D-Printed inlays

myLean creates the 3D-Printed inlays in the Colours:

black, blue-black, green-black, red-black, yellow-black, grey-black and black-ESD

Heights:

0-350 mm freely selectable

Other colours or insert heights on request.

The 3D-printed inlays can be customized by you.

There are also no limits when it comes to labeling.

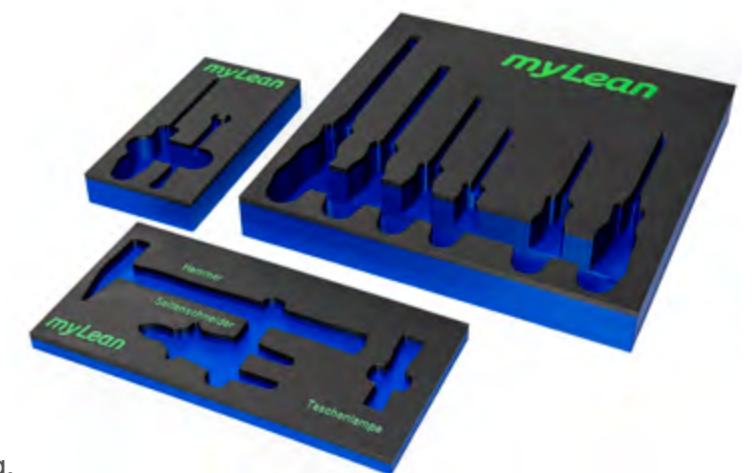



Secure and organised storage with our Shadowboards

With our 10 years of experience in foam processing, we are the perfect partner in the realization for customers from every sector. myLean produces approx. 30,000 foam inserts every year.

Alternative 1

You rent our mobile scanner

Alternative 2

You buy our mobile scanner

Alternative 3

You send us your tools by parcel service and we scan them

Alternative 4

A myLean employee visits to you with our mobile scanner and scans your tools on site

Alternative 5

You send us the CAD production data of your tools



Shadowboards from experts

We have the exact and best solution for every wish. Our specialist staff will scan your products with millimeter precision and create your chosen shadowboard. We are happy to come to your company for scanning or you can send us your products for scanning. With our shadowboards you can create a new sense of order and cleanliness at every individual workstation.

Inlays for drawers

Shadowboards for your tool cabinets, tool trolleys and workstations for a better structure and overview.



3D-Printed inlays

Portable 3D printed inlays offer robust and durable applications. The 3D printing process enables lightweight but stable structures through optimised material usage and complex designs.

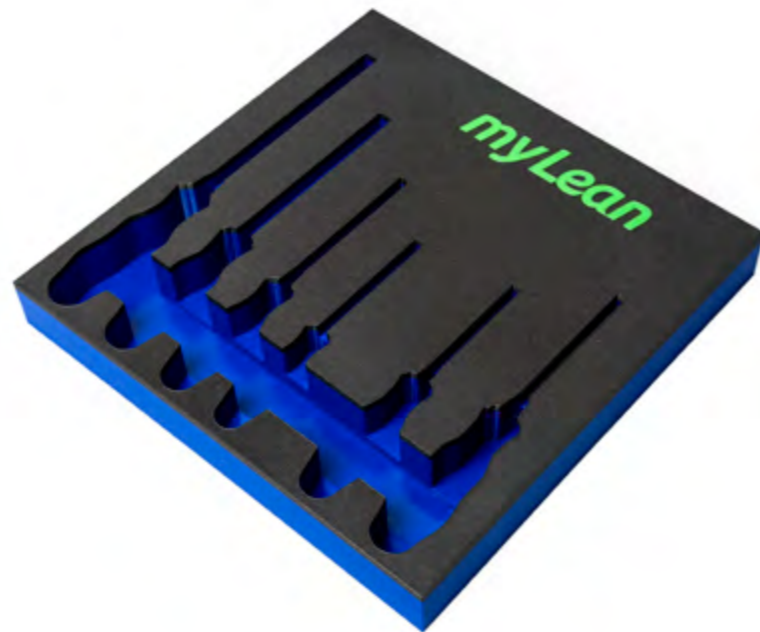

Hard plastic inlays

Hard plastic inlays are ideal for clean-rooms and workstations with high access frequency. Where foam shadowboards reach their limits, hard plastic inlays offer a real alternative. They are abrasion-resistant, oil-resistant and water-resistant, which means they can also be cleaned in the dishwasher. No deformation due to the high density of the material.

5S Shadow glue



Ideally suited for perforated boards or walls. Missing and incorrectly positioned tools or other utensils are immediately visible and access times are reduced. The shadow stickers are applied by simply peeling off the backing paper and sticking them in the desired position.



5S Shadow magnet



Ideally suited for all magnetic surfaces. Missing and incorrectly positioned tools or utensils are immediately visible and access times are reduced. The shadow magnets are simply attached to the desired magnetic location.

Mobile Scanner

Simply put together your own customised shadowboard, hard plastic inlay, shadow adhesive or shadow magnet. All you need is the mobile scanner from myLean.

contents: LED light panel, digital camera, digital operating instructions, USB stick with Shadowboard-Creator, connection cable, USB data cable, free software

Item-No. 10001005



Mobile XXL-Scanner

Simply put together your own customised shadowboard, hard plastic insert, shadow adhesive or shadow magnet for particularly large workpieces. All you need is the mobile XXL scanner from myLean.

Contents: LED light panel, digital camera, digital operating instructions, USB stick with Shadowboard-Creator, connection cable, USB data cable, free software

Item-No. 10002257



Photo accessories for scan unit

Razor-sharp pictures with the photo accessories for professional use

Contents: High-resolution industrial camera, camera software, remote release (Items may differ from the picture)

Item-No. 10002115



Professional scan unit

Use the practical professional scanning unit as a stand-alone solution with an integrated holder for the high-resolution industrial camera (can be purchased separately). Shadows are minimised by the housing and the holder for the high-resolution industrial camera is installed at the optimum distance so the best possible scanning results are achieved. Thanks to the remote shutter release and digital data transfer you can easily photograph and scan your tools from your desk. With our Shadowboard-Creator, you can create your own shadowboards and adapt them to suit your requirements.

Contents: Aluminium photo booth measuring 800 x 800 x 2000 mm.

Consisting of: myLean LED light panel, user manual, USB stick with myLean Shadowboard-Creator, cable

Item-No. 10002114



Mobile tripod

You can photograph your tools, small parts or other objects anywhere, quickly and without blurring. The mobile tripod from myLean has a holding device for the camera and the mobile scanner.

Due to the fixation of the camera and the predefined distance the accuracy and quality of the shadowboards is extremely increased. When folded, the stand serves as a transport trolley for the scanner. The wheels are ESD-compatible.

Item-No. 10001006



Suitcase inlays

The myLean foam inserts are customised and manufactured to the exact dimensions and requirements of your case. Each element is custom cutted so that it fits perfectly into the case and your tools or equipment are optimally protected and organised.

(Item-No. – Customised)



Hanging tray

The myLean hanging tray is used as a mobile picking and goods tray or as a mobile measuring equipment tray directly at the measuring station or workstation. Thanks to the brackets attached on both sides, the mobile hanging tray can be hung practically anywhere.

ca. 400 x 200 x 95 mm
Item-No. 30001104 (Alu red)



Product tray

myLean product trays are used for many different applications. Perfect for the provision of tools, as an exchangeable insert for drawers, for material provision or for targeted tool dispensing to your employees. The goods trays can be stacked on request and therefore they are very space saving. They are manufactured to customer specifications in various lengths and widths.

(Item-No. – Customised)

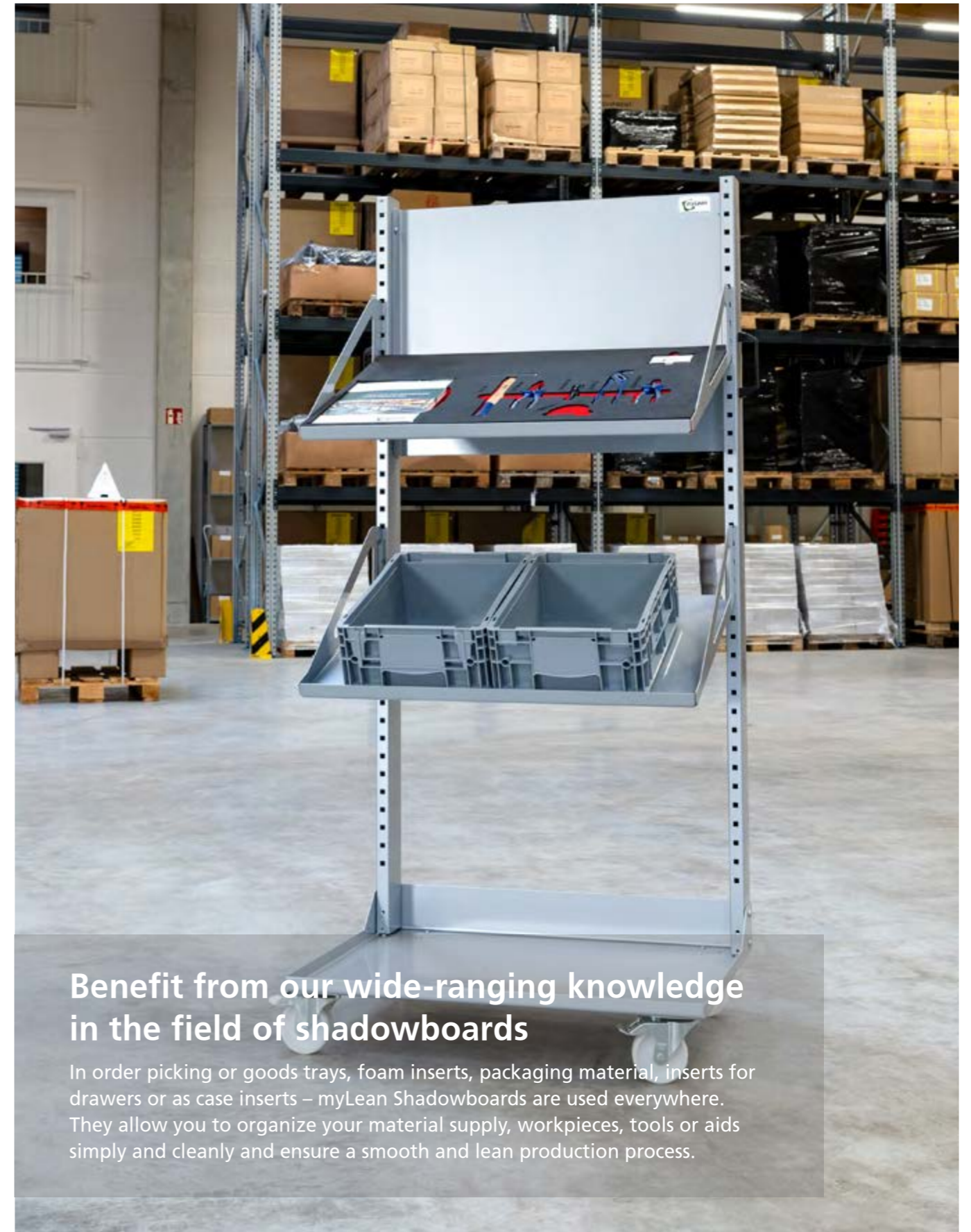

Benefit from our wide-ranging knowledge in the field of shadowboards

In order picking or goods trays, foam inserts, packaging material, inserts for drawers or as case inserts – myLean Shadowboards are used everywhere. They allow you to organize your material supply, workpieces, tools or aids simply and cleanly and ensure a smooth and lean production process.

— Space saving and cleverly organised

- 22 – 23 cleanTower
- 24– 25 cleanTower Flexi
- 26 – 27 cleanTower Quick
- 28 – 29 First-AidTower
- 30 – 31 cleanTower Mobile
- 32 – 36 Accessories
- 37 Broom holder

— The station for all areas

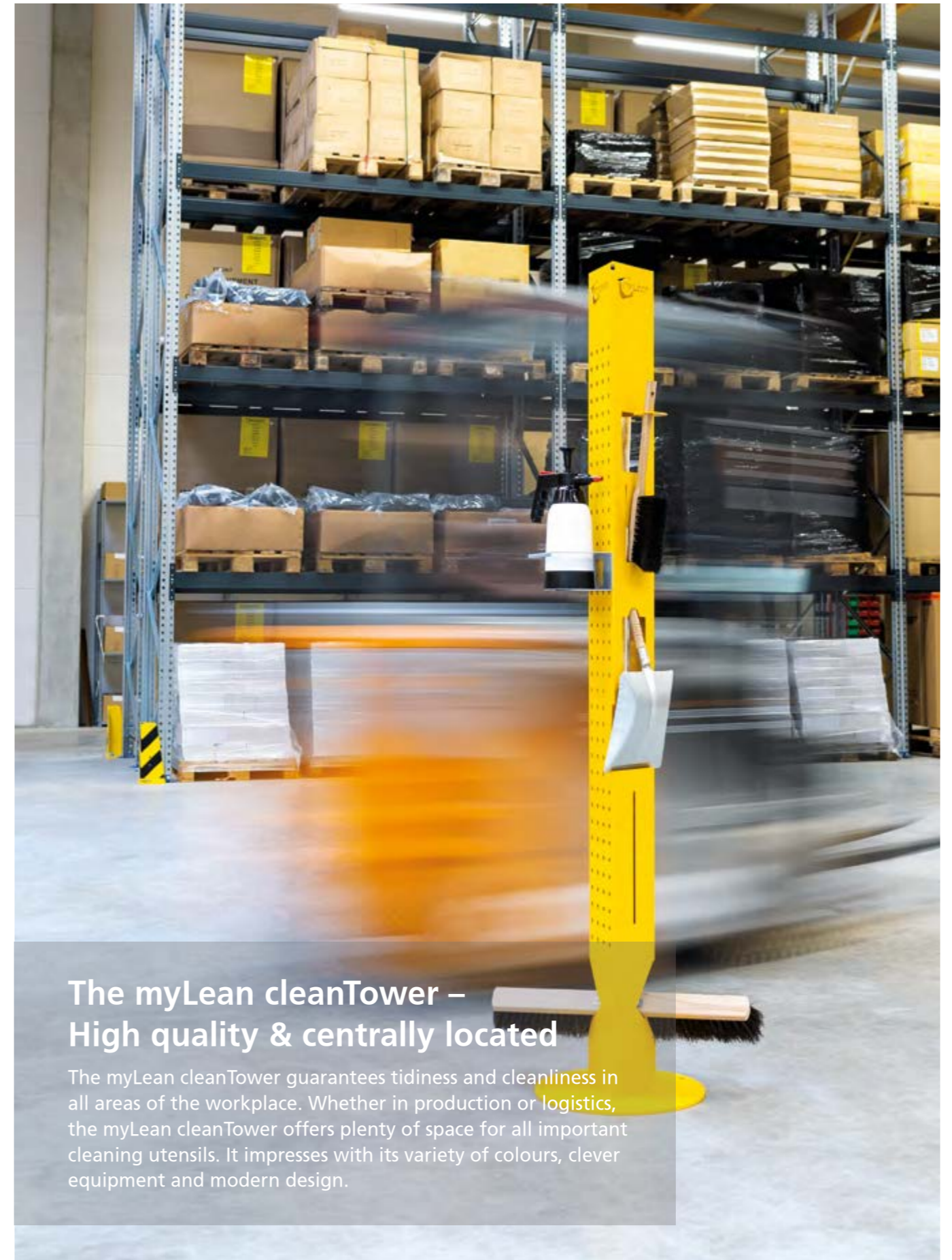

The myLean cleanTower – High quality & centrally located

The myLean cleanTower guarantees tidiness and cleanliness in all areas of the workplace. Whether in production or logistics, the myLean cleanTower offers plenty of space for all important cleaning utensils. It impresses with its variety of colours, clever equipment and modern design.

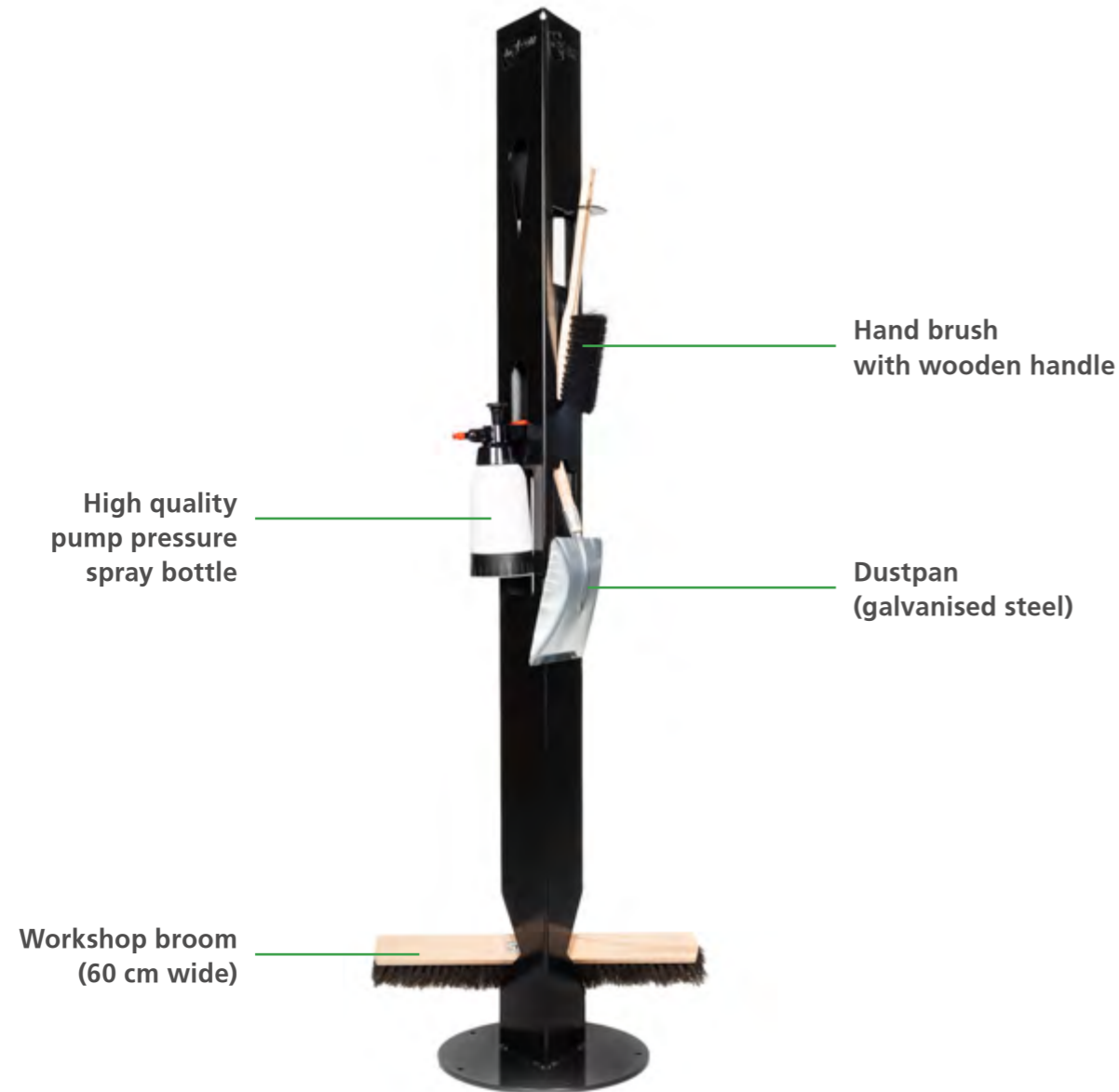

myLean cleanTower

The myLean cleanTower guarantees tidiness and cleanliness in all areas of the workplace. Whether in production or logistics, the myLean cleanTower offers plenty of space for all important cleaning utensils. It impresses with its variety of colours, clever equipment and modern design.

The myLean cleanTower is made of high-quality steel. With a height of 191 cm and a width of approx. 16 cm, it weighs approx. 25 kg including equipment. The 40 cm round base plate guarantees optimum stability. Our mobile myLean cleanTower is available on request.



The myLean cleanTower – Eye-catcher guarantee

You can also simply order your myLean cleanTower in the colour of your choice. The steel is powder-coated in the colour of your choice (available from 6 pieces).

Colour options
Our standard colours are:
black | red | yellow | silver

Features	
Item-No.	10001004 black 10001000 red 10001003 yellow 10001002 silver
Weight	25 kg
Measurements	191 cm x 16 cm x 40 cm
Accessories (included)	Broom, pump pressure spray bottle, dustpan, hand brush
Miscellaneous	5 holes in base plate for floor fixings or castors

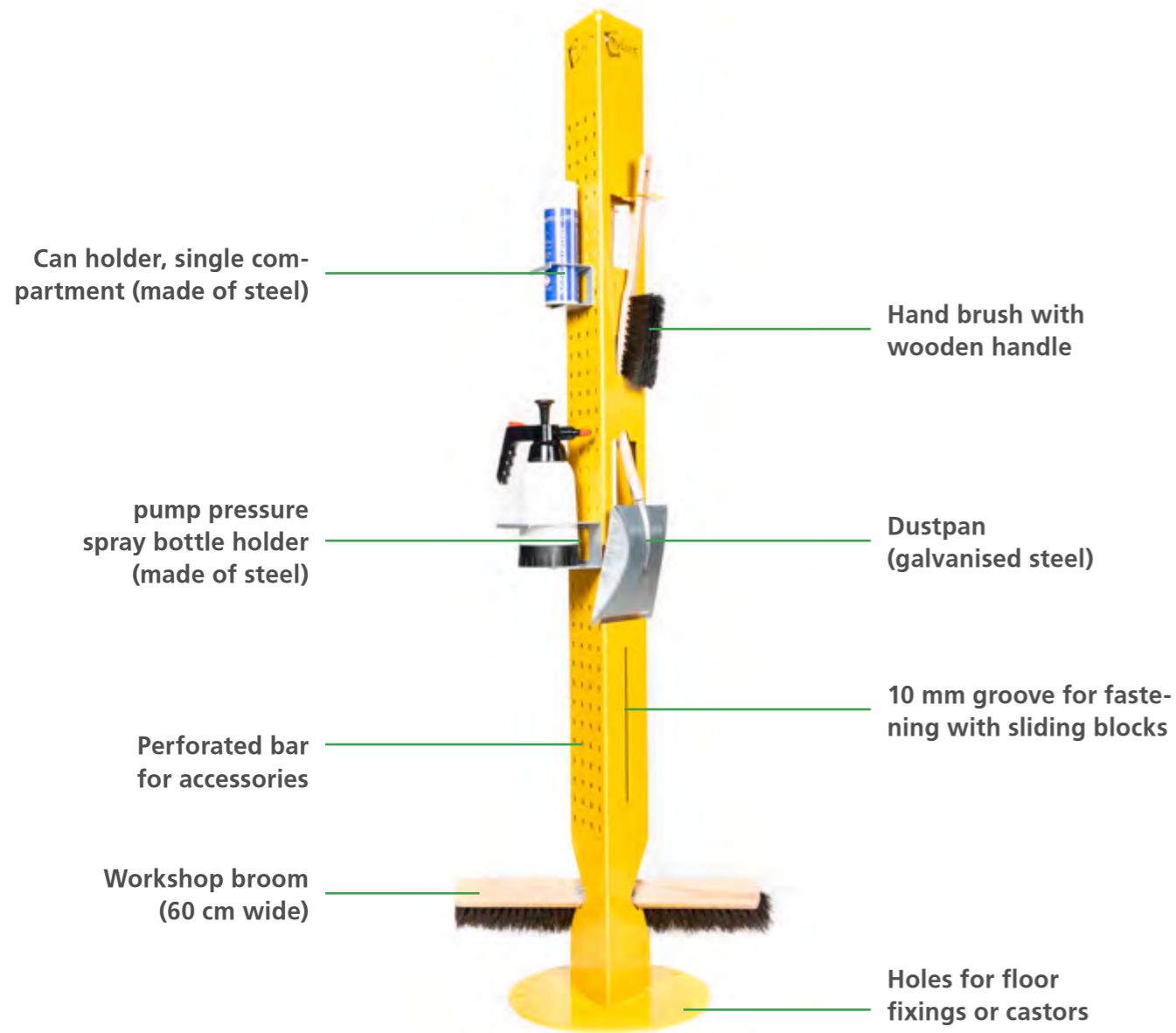

myLean cleanTower Flexi

The myLean cleanTower Flexi is ideal for all areas where different cleaning accessories are required. Whether in production, assembly, quality control, outgoing goods or other areas of the company, the myLean cleanTower Flexi can be customised and assembled to your individual requirements thanks to its clever modular design.

The myLean cleanTower Flexi is made of high-quality steel. The 40 cm round base plate guarantees optimum stability. The side of the myLean cleanTower Flexi has a perforated bar to which the accessories for the myLean cleanTower Flexi can be attached. Our mobile myLean cleanTower Flexi are available on request.



The myLean cleanTower Flexi – The flexible solution for tidiness and cleanliness

You can also simply order your myLean cleanTower Flexi in the colour of your choice. The steel is powder-coated in the colour of your choice (available from 6 pieces).

Colour options
Our standard colours are:
black | red | yellow | silver

Features	
Item-No.	10001044 black 10001043 red 10001046 yellow 10001045 silver
Weight	25 kg
Measurements	190 cm x 16 cm x 40 cm
Accessories (included)	Broom, dustpan, hand brush
Miscellaneous	5 holes in base plate for floor fixings or castors

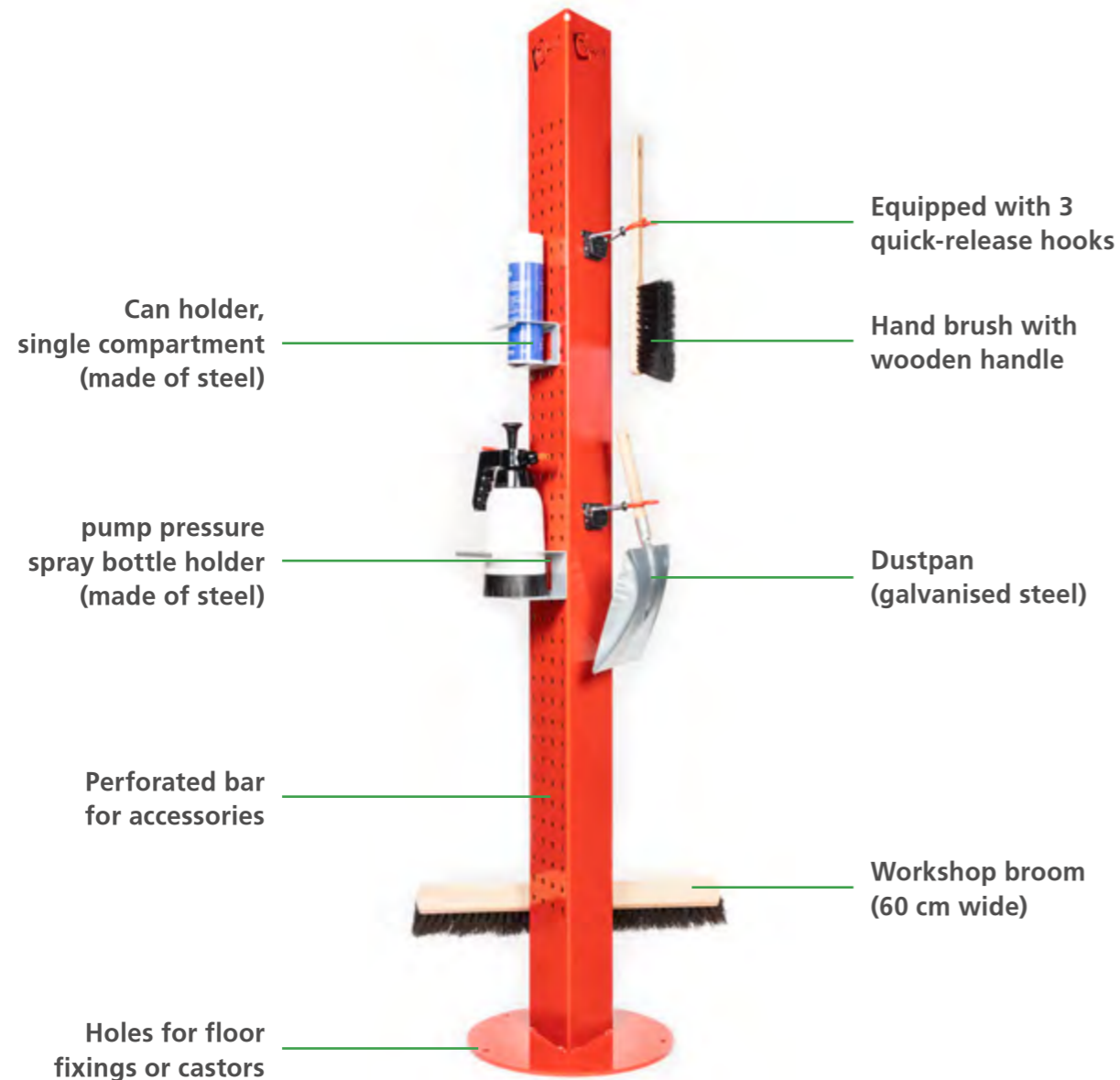

myLean cleanTowers Quick

The myLean cleanTower Quick offers you a quick and flexible solution for storing your individual cleaning utensils. No matter in which area of the company, the myLean cleanTower Quick impresses with its three quick-release hook for effortless attachment of cleaning accessories.

myLean cleanTower Quick can be combined with the appropriate accessories to create a customised myLean cleanTower Quick to suit your requirements and wishes.



The myLean cleanTower Quick – Quick and flexible for more order and cleanliness

You can also simply order your myLean cleanTower Quick in the colour of your choice. The steel is powder-coated in the colour of your choice (available from 6 pieces).

Colour options
Our standard colours are:
black | red | yellow | silver

Features	
Item-No.	10001099 black 10001100 red 10001102 yellow 10001101 silver
Weight	25 kg
Measurements	190 cm x 16 cm x 40 cm
Accessories (included)	Broom, dustpan, hand brush
Miscellaneous	5 holes in base plate for floor fixings or castors

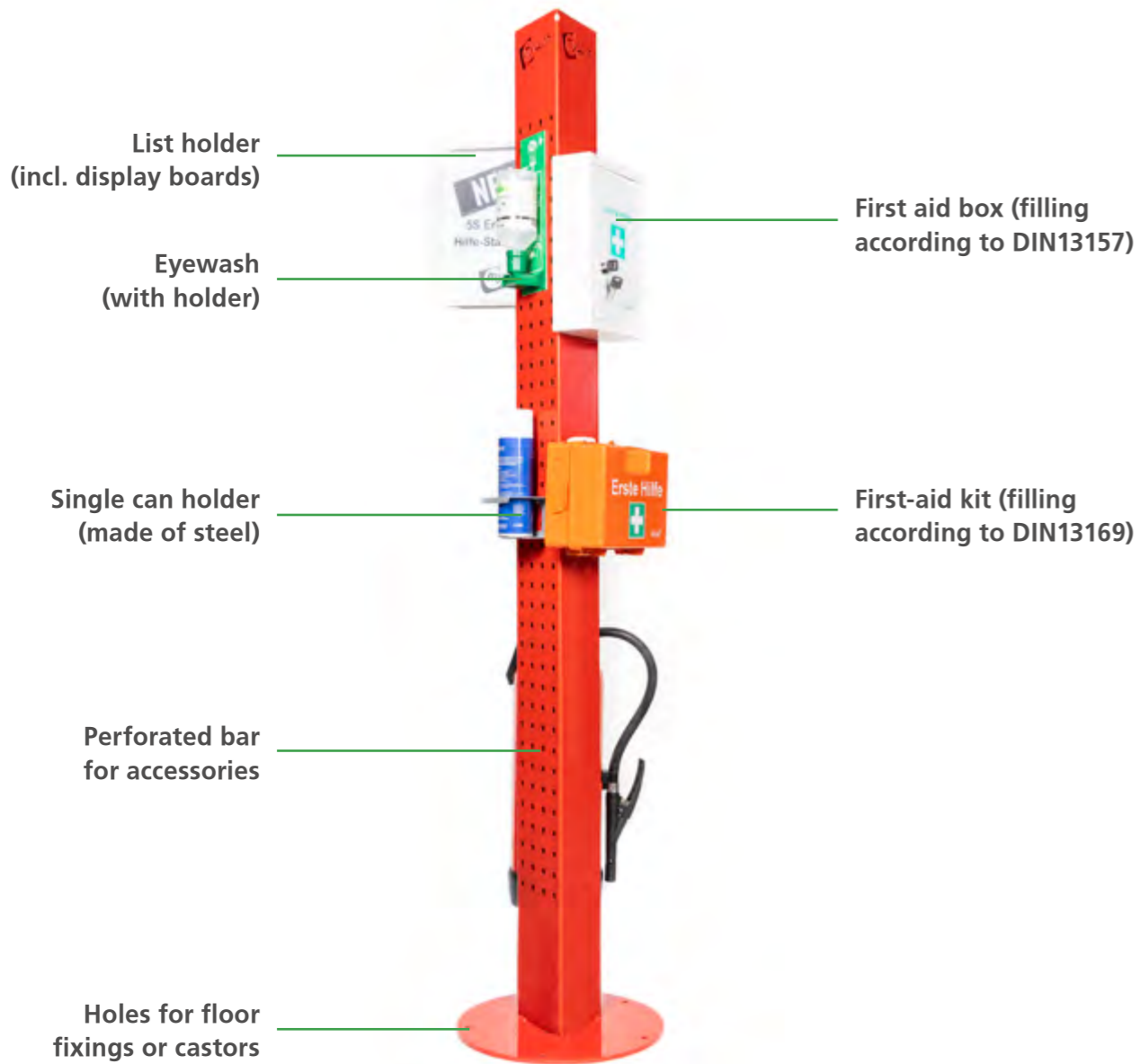

myLean First-AidTower

The first aid station from myLean is ideal for all areas of the company. It impresses with its variety of colours, modern design and space-saving equipment options. The 40 cm round base plate guarantees optimum stability. The first aid station also has a perforated bar on the side, to which our cleanTower accessories can be optionally attached or an eye spray bottle incl. holder (item no.: 30004145).



The myLean First-AidTower – Quick and easy handling in case of accidents

You can also order your myLean First-AidTower in the colour of your choice. The steel is powder-coated in the colour of your choice (available from 6 pieces).

Colour options
Our standard colours are:
black | red | yellow | silver

Features	
Item-No.	10002247 red 10002248 silver 10002249 yellow 10002250 black
Weight	27,5 kg
Measurements	190 cm x 16 cm x 40 cm
Accessories (included)	Angle sign, first aid kit, first aid cabinet, holder for fire extinguisher, list holder with display boards
Miscellaneous	5 holes in base plate for floor fixings or castors

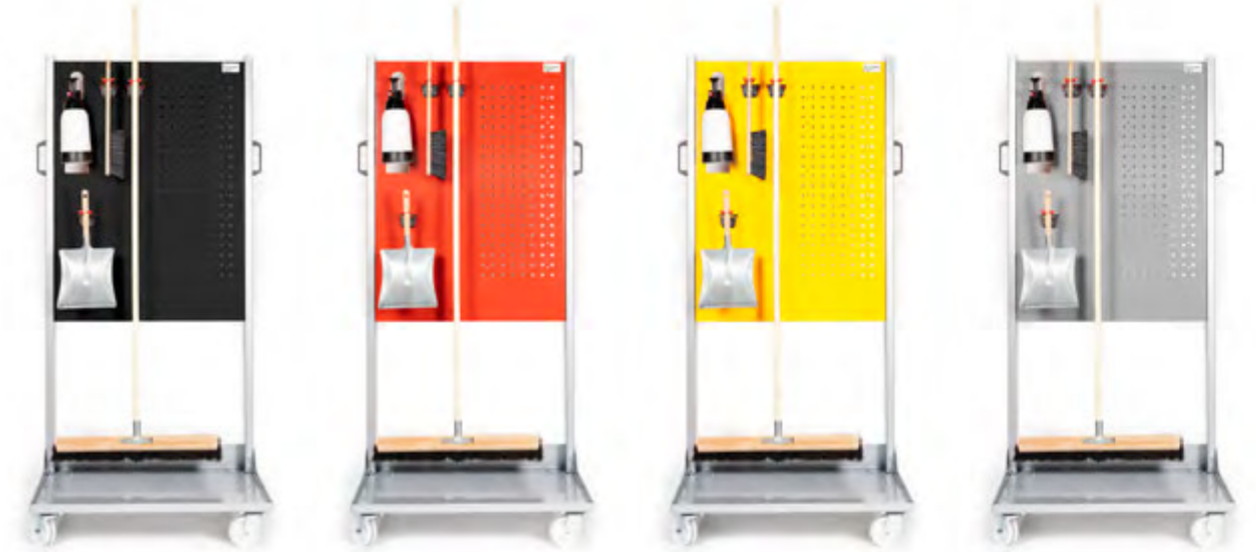
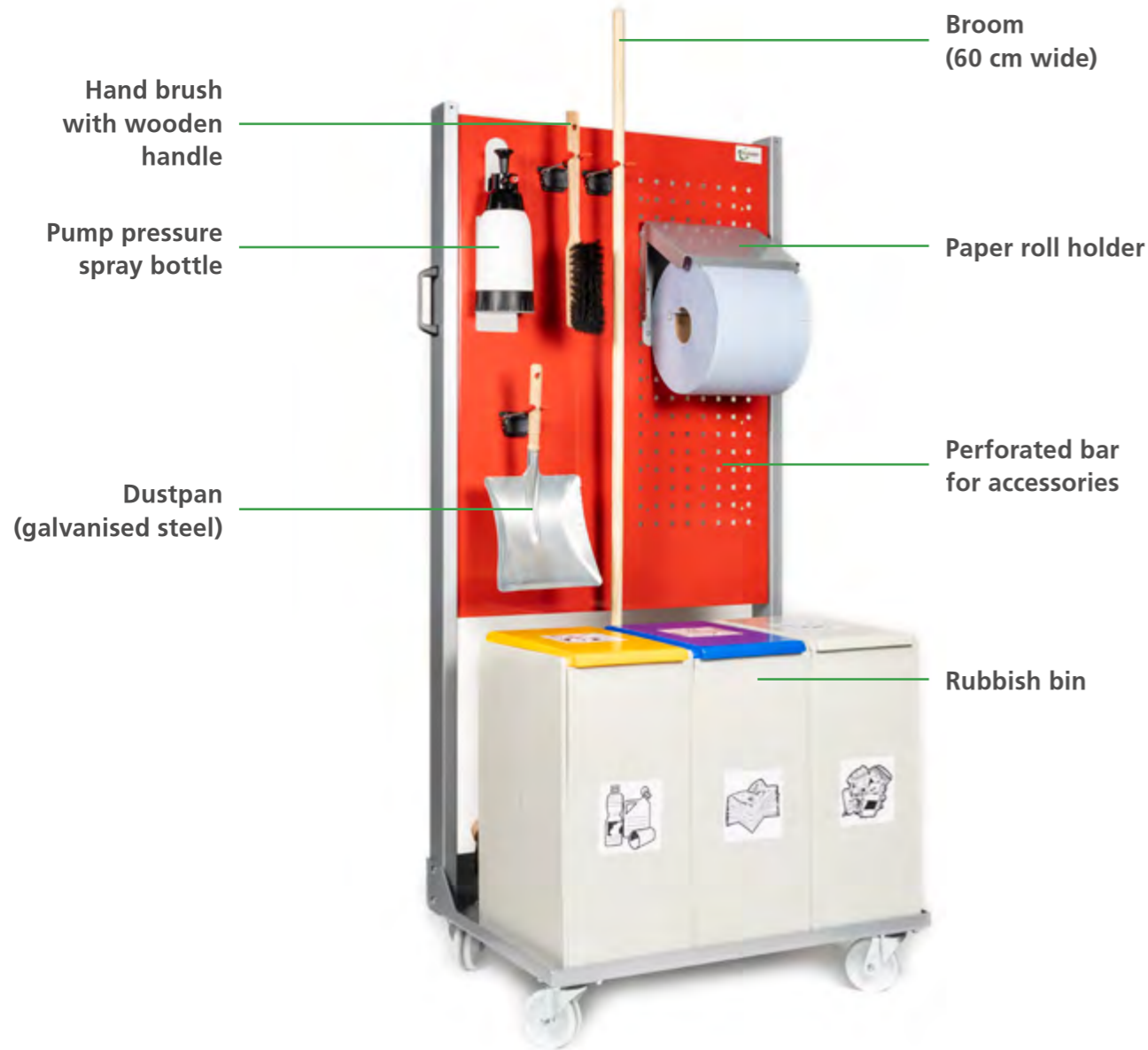

myLean cleanTower Mobile

The myLean cleanTower Mobile offers you a mobile and space-saving solution for storing your individually required cleaning utensils. The myLean cleanTower Mobile impresses with its three attached quick-release hooks, which make it quick and easy to attach the cleaning accessories.

It is also ideal for making optimum use of unused wall space. Thanks to the 4 attached castor wheels it can always be moved to the desired area of use and optionally offers enough space for a single, double or triple waste bin, as well as for your individually required accessories.

The myLean cleanTower Mobile – space-saving and mobile for more order and cleanliness

You can also simply order your myLean cleanTower Mobile in the colour of your choice. The steel is powder-coated in the colour of your choice (available from 6 pieces).

Colour options
The frame of the cleanTower mobile is always silver. Our standard colours are: silver | red | yellow | black

Features	
Item-No.	10002076 black 10002077 red 10002079 yellow 10002078 silver
Weight	50 kg
Measurements	172 cm incl. Rolls 80 cm x 60 cm
Accessories (included)	Broom, pump pressure spray bottle, dustpan, hand brush
Miscellaneous	2 swivel castors 2 fixed castors with brakes

— Accessories cleanTower



Pump pressure spray bottle	
Size	1,5 L
Item-No.	30001008



Hand brush (with long wooden handle)	
Material	Wooden handle, synthetic bristles
Item-No.	30001100



Dustpan	
Material	Galvanised steel, wooden handle
Item-No.	30001101



Broom	
Measurements	60 cm wide
Item-No.	30001102



Water slider	
Measurements	60 cm wide
Item-No.	30004082



ESD castor (incl. brakes & mounting kit)	
Measurements	Ø 50 mm
Item-No.	30001507



Castor wheel (incl. mounting kit)	
Measurements	Ø 50 mm
Item-No.	30002930

Items may differ from illustrations

— Accessories cleanTower



Chute (grey)	
Measurements	90 x 120 x 60 mm
Item-No.	30001310



Chute Cleaning rags (grey)	
Measurements	115 x 165 x 110 mm
Item-No.	30001414



Chute (grey)	
Measurements	240 x 210 x 100 mm
Item-No.	30001440



Bin bag holder (70 L)	
Measurements	376 x 376 x 60 mm
Item-No.	30001504



Hook (grey)	
Measurements	55 x 28 x 8 mm
Item-No.	30001422



Hook (grey)	
Measurements	55 x 128 x 8 mm
Item-No.	30001506



Can holder (grey)	
Measurements	90 x 100 x 77 mm
Hole-Ø	70 mm
Item-No.	30001311



Can holder (grey)	
Measurements	90 x 185 x 77 mm
2x Hole-Ø	70 mm
Item-No.	30001312



Can holder (grey)	
Measurements	90 x 270 x 75 mm
3x Hole-Ø	70 mm
Item-No.	30001442



Pump bottle holder	
Measurements	130 x 130 x 87 mm
Hole-Ø	103 mm
Item-No.	30001415



Pump bottle holder	
Measurements	160 x 160 x 87 mm
Hole-Ø	120 mm
Item-No.	30001441



Pump bottle holder myLean	
Measurements	160 x 160 x 87 mm
Hole-Ø	131 mm
Item-No.	30001508



First-Aid kit (Filling according to DIN 13169)	
Measurements	280 x 190 x 125 mm
Item-No.	30004319



First-Aid Box (Filling according to DIN 13158)	
Measurements	320 x 220 x 80 mm
Item-No.	30004320



List holder	
Measurements	75 x 320 x 30 mm
Item-No.	30001312



Display panels	
Measurements	75 x 320 x 30 mm
Item-No.	30001312



Eye spray bottle incl. holder	
Measurements	30 x 90 x 60 mm
Item-No.	30004145

Items may differ from illustrations



Paper roll holder	
Measurements	240 x 280 x 30 mm
Item-No.	30002550

Paper roll (1.000 sheets, perforated)	
Measurements	Width: 220 mm Ø 285 mm
Item-No.	30002900



Single rubbish bin	
Measurements	570 x 205 x 405 mm
Item-No.	10002083



Double rubbish bin	
Measurements	570 x 505 x 405 mm
Item-No.	10002084



Triple rubbish bin	
Measurements	570 x 760 x 405 mm
Item-No.	10002085



Waste bin insert	
Measurements	290 x 220 x 530 mm
Material	Galvanised steel
Item-No.	30002979

Items may differ from illustrations



Broom holder for wall mounting

Benefit from our broom holder now. Brooms standing around not only take up unnecessary space, but also pose a safety risk. You can avoid this with our broom holder, which can be easily mounted on the wall. (Thanks to simple wall mounting, you can easily install the broom holder.)

Material: Galvanised steel
 Measurements: ca. 260 x 100 x 95 mm
 Hole-Ø: 6,4 mm
Item-No.: 30002783



- 40 General features
- 41 Floor mats customise
- 42 – 43 Flow
- 44 – 45 Flat
- 46 – 47 Smooth
- 48 – 49 Luxury
- 50 – 51 Pearl
- 52 – 53 Harmony
- 54 Vario
- 55 Icon Legend

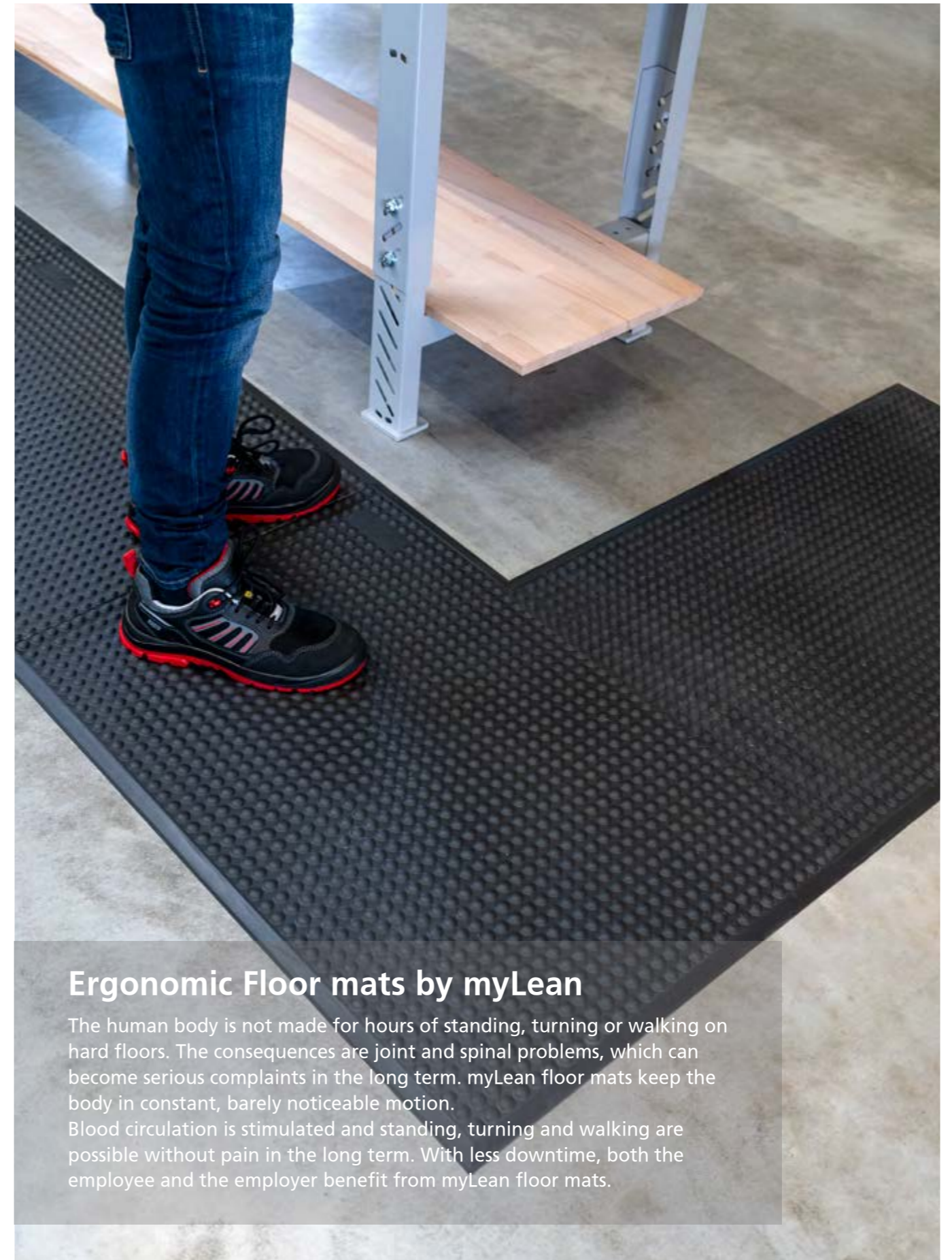

Ergonomic Floor mats by myLean

The human body is not made for hours of standing, turning or walking on hard floors. The consequences are joint and spinal problems, which can become serious complaints in the long term. myLean floor mats keep the body in constant, barely noticeable motion.

Blood circulation is stimulated and standing, turning and walking are possible without pain in the long term. With less downtime, both the employee and the employer benefit from myLean floor mats.

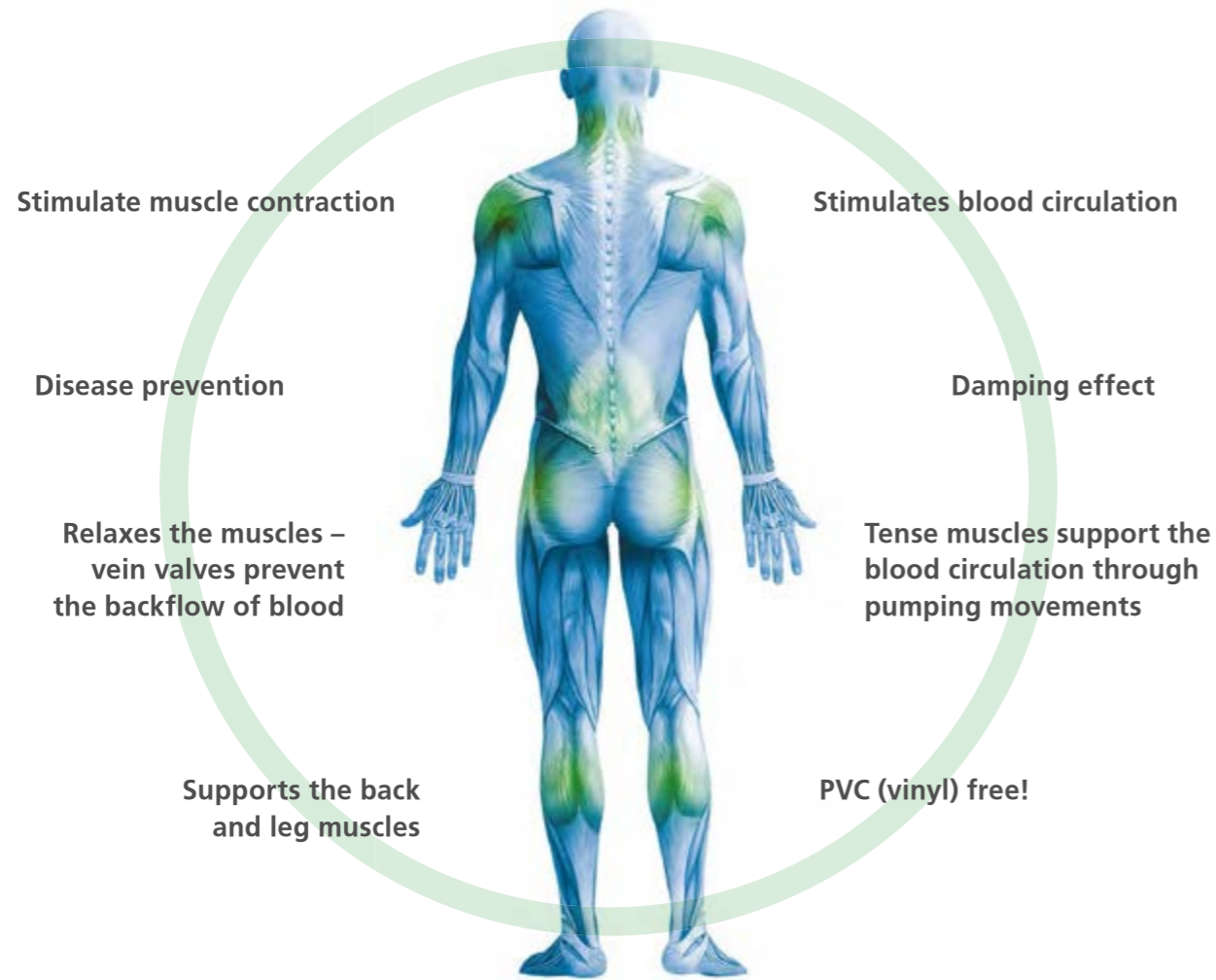

Polyurethane Floor mats

myLean Polyurethane mats offer maximum comfort, top quality and elasticity. Specially developed Polyurethane and the high-density outer skin ensure a long service life. The floor mats can be safely laid out in damp and wet areas.

Rubber Floor mats

Variations myLean rubber mats

- Synthetic rubber made from nitrile (NBR): Resistant to oil, cooling lubricants and chemicals, i.e. long service life
- SBR mats: low abrasion
- Natural rubber (NR): highly elastic, good tear resistance, low-wear
- myLean rubber compounds consist of a mixture and construction specially tailored to the area of application



The right floor mat for every application and every area of use!

With different surfaces and different undersides, the floor mats can be selected for the appropriate load and application. We produce customer-specific floor mats with special colours and individual shapes.

Customise your floor mat specifically for your needs

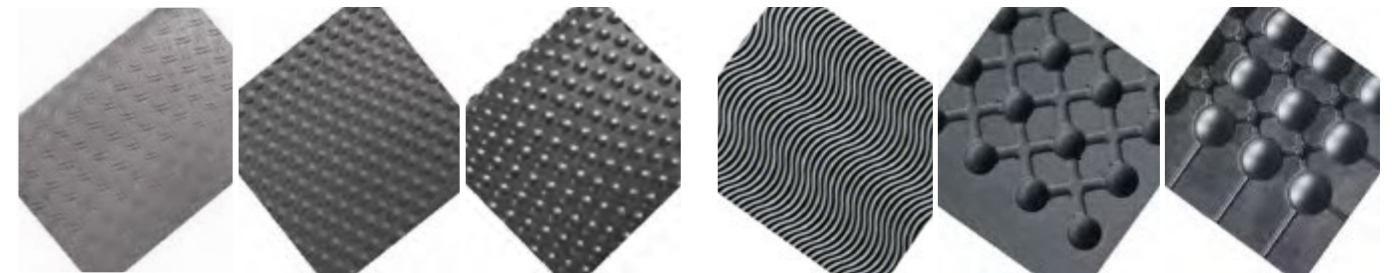

Various surfaces

Various subpages

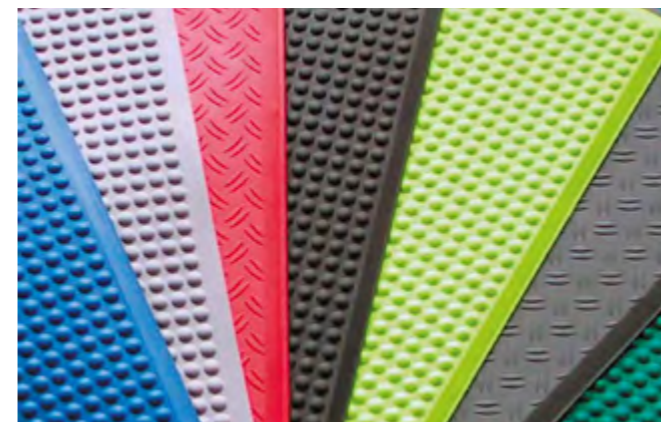

Special colours

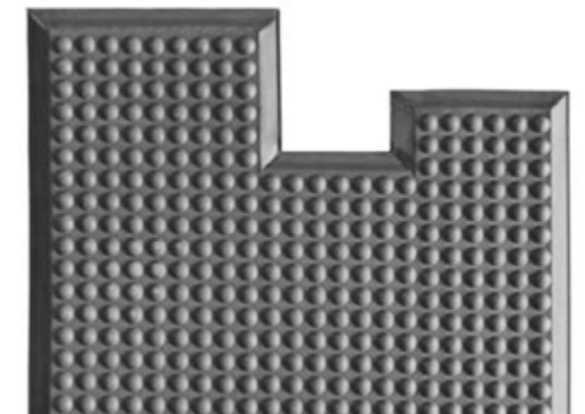

Different shapes

Flow a (30001075)

Flow A (30001076)

Flow AF (30001077)

Ergonomic floor mat – For standing and walking workstations in wet and dry areas.

- Extremely elastic
- Hard-wearing mat with nub surface
- Corrugated, grooved underside profile - slip-resistant
- Long service life due to thick, highly compressed outer skin

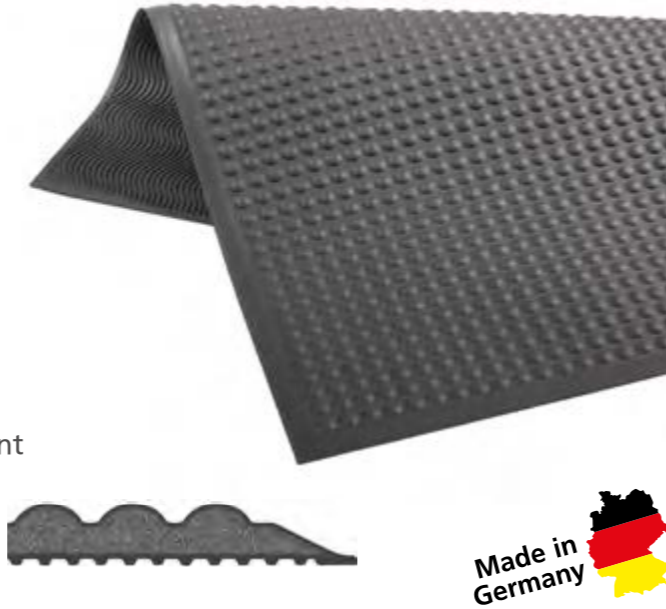

The Flow floor mat is designed for heavy-duty usage. (multi-shift workstations)

Features

Hydrolysis-resistant, slip-resistant R10, surefooted, cold-insulating, stimulates blood circulation, CFC & HCFC-free, shock-absorbing, low-wear, limited resistance to acids and oils, largely resistant to chemicals, bases and alkalis

Application areas

Assembly lines, at workbenches and machines, sorting and packaging systems or behind sales counters (offices, banks, counters), etc.

Versions

Flow a $10^9 \Omega$ Standard features antistatic/low charge
Flow A $10^7 \Omega$ ESD electrostatically dissipative
Flow AF $10^7 \Omega$ ESD electrostatically dissipative, fire-retardant B1

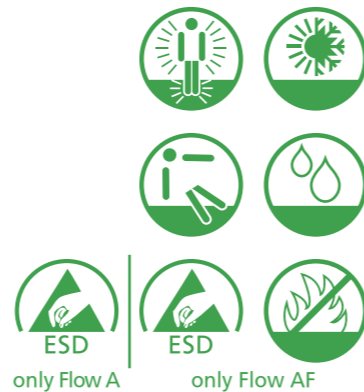

Features	
Material	Polyurethane, highly elastic, with thick highly compressed outer skin
Surface	Nubs
Bottom surface	Groove profile
Colour	Anthracite
Measurements	ca. 60 x 90 cm, plus 2 cm Inclined approach, custom sizes available
Height	ca. 15 mm
Weight	ca. 2,6 kg
Warranty	5 years (on material and workmanship with proper use, excluding wear and tear)

Soft Flow a (30001081)

Soft Flow aF (30001082)

Supports the back and leg muscles and is suitable for dry and damp areas.

- Standing and walking workstations
- Nub structure for more slip resistance
- Grooved underside for high slip resistance
- Exceptionally elastic

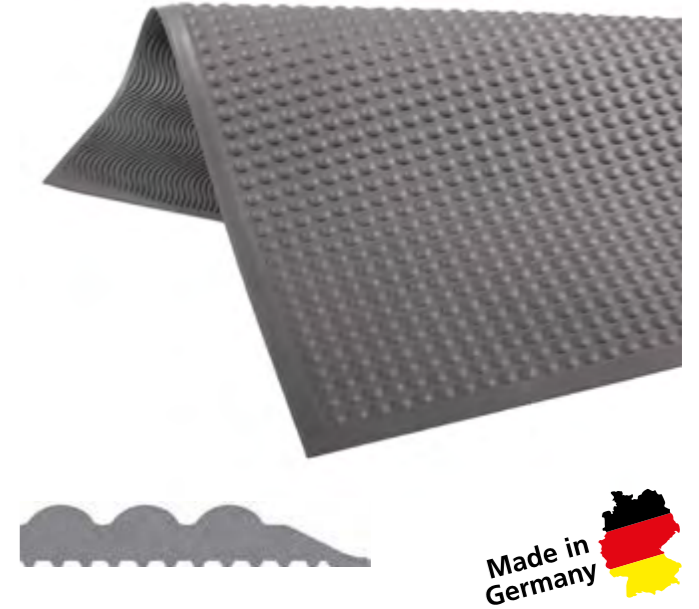

The Soft Flow floor mat is designed for normal usage.

Features

Surefooted, anti-slip RH 10, hydrolysis-resistant, CFC and HCFC-free, stimulates blood circulation, cold-insulating, shock-absorbing, largely resistant to chemicals, bases and alkalis, limited resistance to acids and oils

Application areas

Assembly stations, workbenches, sorting systems and machines, sales counters (offices, banks, counters), etc.

Versions

Soft Flow a $10^9 \Omega$ Standard features antistatic/low charge
Soft Flow aF $10^9 \Omega$ antistatic/low charge, fire-retardant B1



Features	
Material	Polyurethane, highly elastic
Surface	Nubs
Bottom surface	Groove profile, slip-resistant
Colour	Graphite-grey
Measurements	ca. 60 x 90 cm, plus 2 cm Inclined approach, custom sizes available
Height	ca. 14 mm
Weight	ca. 2,2 kg
Warranty	3 years (on material and workmanship with proper use, excluding wear and tear)

Flat a (30001078)

Flat A (30001079)

Flat AF (30001080)

Standing, walking and turning workstations (with many turning movements). Suitable for dry and damp areas.

- Easy to drive on
- High standing comfort due to wavy grooved profile
- Grooved profile on the bottom surface prevents floating in wet conditions
- Easy to clean
- Long service life thanks to thick, highly compacted outer skin



The Flat floor mat has been developed for heavy-duty usage. (multi-shift workstations)

Features

Slip-resistant, hydrolysis-resistant, anti-slip R10, CFC and HCFC-free, cold-insulating, low-wear, stimulates blood circulation, largely resistant to chemicals, bases and alkalis, limited resistance to acids and oils

Application areas

Assembly lines, workbenches, machines, order picking systems, sales counters (offices, banks, counters), etc.

Versions

Flat a 10⁹ Ω Standard features antistatic/low charge
Flat A 10⁷ Ω ESD electrostatically dissipative
Flat AF 10⁷ Ω ESD electrostatically dissipative, fire-retardant B1



Features	
Material	Polyurethane, highly elastic, with thick highly compressed outer skin
Surface	Ripple structure
Bottom surface	Groove profile
Colour	Anthracite
Measurements	ca. 60 x 90 cm, plus 2 cm Inclined approach, custom sizes available
Height	ca. 12 mm
Weight	ca. 2,6 kg
Warranty	5 years (on material and workmanship with proper use, excluding wear and tear)

Soft Flat a (30001083)

Soft Flat aF (30001084)

Supports the back and leg muscles and is suitable for dry and damp areas.

- For workstations with many turning movements
- Access with light supply vehicles possible
- Easy to clean



The Soft Flat floor mat is designed for normal usage.

Features

Surefooted, anti-slip R10, hydrolysis-resistant, CFC and HCFC-free, stimulates blood circulation, cold-insulating, shock-absorbing, largely resistant to chemicals, bases and alkalis, limited resistance to acids and oils

Application areas

Assembly stations, workbenches, sorting systems and machines, sales counters (offices, banks, counters), etc.

Versions

Soft Flow a 10⁹ Ω Standard features antistatic/low charge
Soft Flow aF 10⁹ Ω antistatic/low charge, fire-retardant B1



Features	
Material	Polyurethane, highly elastic
Surface	Ripple structure
Bottom surface	Groove profile, anti-slip
Colour	Graphite-grey
Measurements	ca. 60 x 90 cm, plus 2 cm Inclined approach, custom sizes available
Height	ca. 12 mm
Weight	ca. 2,2 kg
Warranty	3 years (on material and workmanship with proper use, excluding wear and tear)

— Smooth

Smooth a (30001072)

Smooth A (30001073)

Smooth AF (30001074)

Standing, walking and turning workstations thanks to flattened nubs. Suitable for dry and damp areas.

- Enormously cushioning due to material and special construction with air cushion effect thanks to hollow nubs
- Stimulates blood circulation
- Relaxed and fatigue-free standing thanks to flattened nubs
- Long service life thanks to thick, highly compressed outer skin

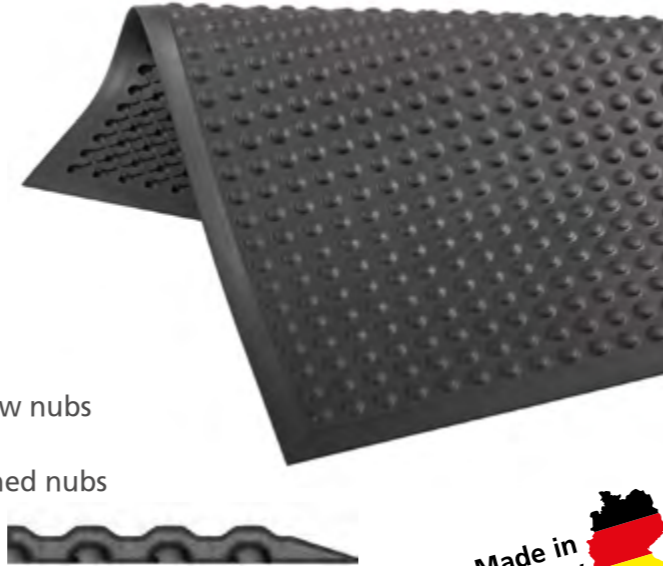

Developed for heavy-duty usage. (Multi-shift workstations)

Features

Hydrolysis-resistant, slip-resistant R10, slip-resistant, cold-insulating, stimulates blood circulation, CFC and HCFC-free, shock-absorbing, low-wear, limited resistance to acids and oils, largely resistant to chemicals, bases and alkalis

Application areas

Walking, standing & turning workstations, assembly & packaging lines, machines, sales & checkout counters, laboratories, sorting systems, etc.

Versions

Smooth a 10⁹ Ω Standard features antistatic/low charge
Smooth A 10⁷ Ω ESD, Dischargeable
Smooth AF 10⁷ Ω ESD, Electrostatic discharge/fire-retardant B1



only Smooth A only Smooth AF

Features	
Material	Polyurethane, highly elastic, with thick highly compressed outer skin
Surface	Flattened nubs
Bottom surface	Hollow nubs with drainage channels, anti-slip
Colour	Anthracite
Measurements	ca. 60 x 90 cm, plus 2,5 cm Inclined approach, custom sizes available
Height	ca. 14 mm
Weight	ca. 2,6 kg
Warranty	5 years (on material and workmanship with proper use, excluding wear and tear)

— Luxury

Luxury S (30001085)

Luxury Sg (30001086)

All-round floor mat – Ergonomic nitrile mat for machining areas.

- Comfortable walking, standing and turning
- Extremely hard-wearing floor mat
- Drainage channels between the nubs for better drainage of liquids
- Practical for shift operation in dry and wet areas
- Can be accessed with pallet trucks and replenishment vehicles
- Luxury Sg with signalling effect at the edge

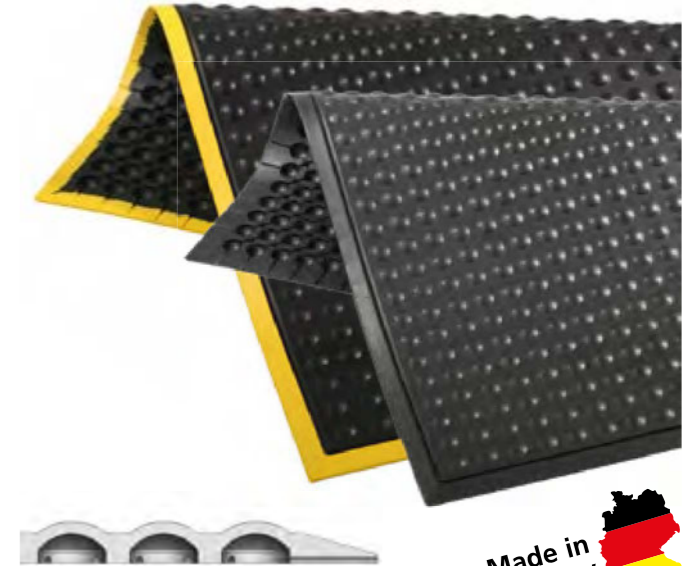

Features

Surefooted, anti-slip, cold-insulating, stimulates blood circulation, hydrolysis-resistant, resistant to chemicals, oil and cooling lubricants, easy to clean, low-wear

Application areas

CNC machines, lathes, cleaning systems, milling systems, machining areas, welding workstations, workstations with cooling lubricants, etc.

Leakage resistance

10⁹ Ω antistatic/low charge



Features	
Material	Nitrile rubber (NBR)
Surface	Flattened nubs
Bottom surface	Hollow flat nubs with drainage channels
Colour	Luxury S: black Luxury Sg: black with all-round yellow rim
Measurements	Ca. 60 x 90 cm, plus 2,5 cm Inclined approach, custom sizes available
Height	ca. 14 mm
Weight	ca. 5,0 kg
Warranty	5 years (on material and workmanship with proper use, excluding wear and tear)

Floor mats

— Luxury KL

Luxury KL (30001087)

Ergonomic nitrile mat with cork granules

- Very well suited for workplaces with increased oil and cooling lubricant production, in dry and wet areas.
- Risk of slipping is minimised thanks to cork granules
- Comfortable standing, walking and turning
- Perforated between the nubs for better drainage of liquids
- Can be driven on with light transport trolleys



Extremely resistant for harsh industrial industrial usage. (Ideal for shift operation)

Features

Surefooted, anti-slip, cold-insulating, foot-massaging, hydrolysis-resistant, stimulates blood circulation, very low wear, resistant to many chemicals and cooling lubricants, very durable

Application areas

CNC machines, lathes, cleaning systems, milling systems, machining areas, etc.

Electrical resistance

10⁹ Ω antistatic/low charge



Features	
Material	Nitrile rubber (NBR) + cork
Surface	Flattened nubs with cork and perforation
Bottom surface	Hollow flat nubs with drainage channels
Colour	Black-cork
Measurements	ca. 60 x 90 cm, plus 2,5 cm Inclined approach, custom sizes available
Height	ca. 14 mm
Weight	ca. 5,0 kg
Warranty	5 years (on material and workmanship with proper use, excluding wear and tear)

Floor mats

— Luxury H

Luxury H (30001088)

Ergonomic hygienic nitrile floor mat

- For dry and wet areas, food and laboratory areas
- Comfortable standing, walking and turning

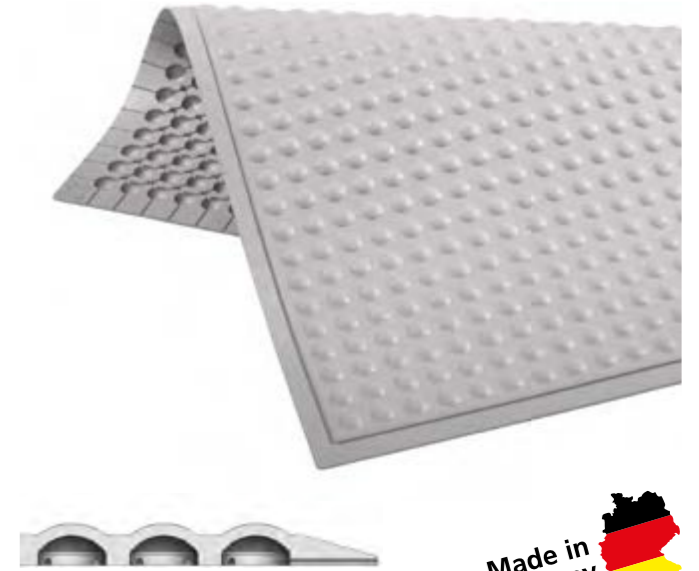

Features

Surefooted, anti-slip, cold-insulating, foot-massaging, hydrolysis-resistant, stimulates blood circulation, very low-wear, resistant to many chemicals and cooling lubricants, very durable, can be disinfected

Application areas

Laboratories, butcher's shops, bakeries, shop counters, food industry, etc.

Electrical resistance

10¹² Ω



Features	
Material	Nitrile rubber (NBR), special compound
Surface	Flattened nubs
Bottom surface	Hollow flat nubs with drainage channels
Colour	Graphite-grey
Measurements	ca. 60 x 90 cm, plus 2,5 cm Inclined approach, custom sizes available
Height	ca. 14 mm
Weight	ca. 5,0 kg
Warranty	3 years (on material and workmanship with proper use, excluding wear and tear)

Pearl Standard (30001093)

Suitable for wet and dirty areas

- Walking, standing and turning workstations
- Continuous large perforation
- Suitable for wet or dirty areas
- Resistant to grease, liquids and oil

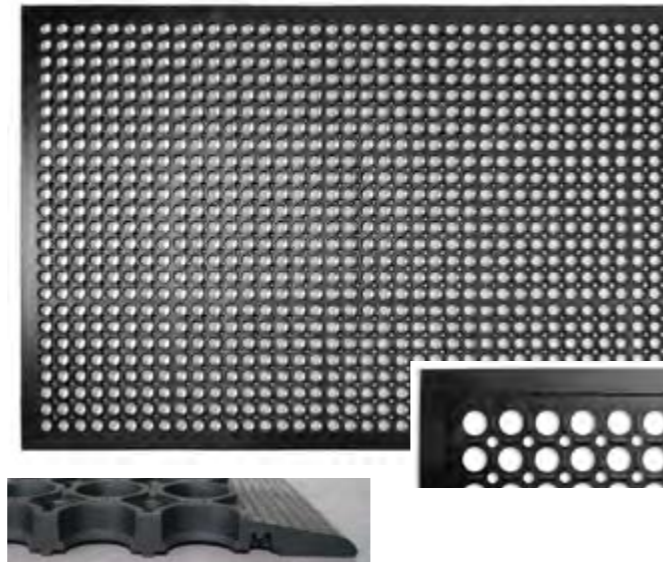

Features
Surefooted, anti-slip, hydrolysis-resistant, limited oil resistance

Application areas
Industrial areas with a high volume of fluids

Leakage resistance
10¹² Ω

Features	
Material	Natural rubber 45 – 50 Shore A
Surface	Continuously perforated surface
Bottom surface	Drainage channels
Colour	Black
Measurements	ca. 151,5 x 91,0 cm, incl. 3,5 cm Inclined approach, custom sizes available
Height	ca. 12 mm
Weight	ca. 8,3 kg
Warranty	2 years (on material and workmanship with proper use, excluding wear and tear)



Pearl Deluxe (30001094)

Suitable for wet and dirty areas

- Walking, standing and turning workstations
- Continuous large perforation
- Suitable for wet or dirty areas
- Resistant to grease, liquids and oil, conditionally suitable for cooling lubricants

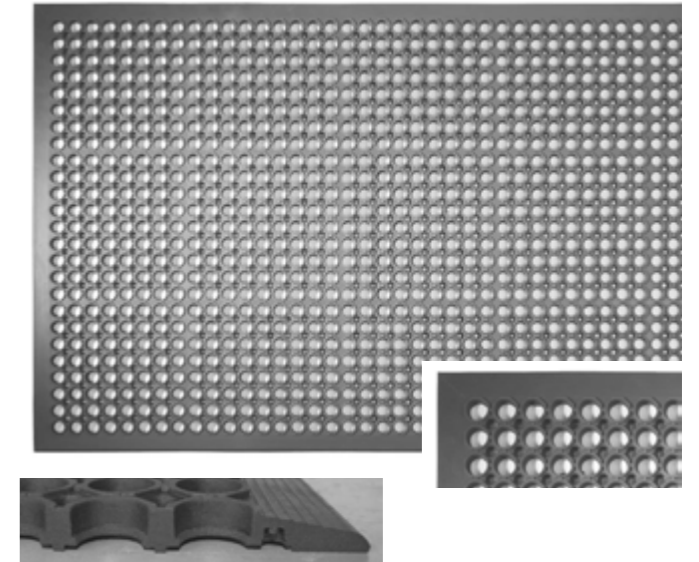

Features
Surefooted, anti-slip, hydrolysis-resistant, oil and grease-resistant, limited suitability for cooling lubricants

Application areas
CNC and machining areas, industrial areas with a high volume of liquids, food industry, slaughterhouses, catering, etc.

Leakage resistance
10¹² Ω

Features	
Material	Natural rubber (NBR) 45 – 50 Shore A
Surface	Continuously perforated surface
Bottom surface	Drainage channels
Colour	Terracotta
Measurements	ca. 151,5 x 91,0 cm, incl. 3,5 cm Inclined approach, custom sizes available
Height	ca. 12 mm
Weight	ca. 8,3 kg
Warranty	2 years (on material and workmanship with proper use, excluding wear and tear)



Harmony Balance (30001095)

Floor mat – Ergonomic with anti-fatigue effect – with nubs that run out – for walking, standing and turning.

- Stimulates blood circulation
- Extremely elastic and hardwearing
- Modern design
- Easy to clean, very long service life
- Mostly chemical and UV-resistant
- Grooved structure on the bottom surface prevents slipping on smooth floors
- Customised shapes and sizes available



Features
Combines the advantages of a polyurethane mat with a very easy-to-clean and robust surface.

Application areas
Clean rooms, laboratories, order picking systems, retail, offices, banks, counters, etc.

Electrical resistance
10⁹ Ω antistatic/low charge

Features	
Material	Top layer of high-strength polyurethane film, high-quality foamed polyurethane
Surface	Flattened nubs
Bottom surface	Groove wave structure, anti-slip
Colour	Silver, blue
Measurements	0,60 m x 0,90 m plus inclined approach (2,5 cm), custom sizes available
Height	ca. 13 mm
Weight	ca. 2,8 kg
Warranty	5 years (on material and workmanship with proper use, excluding wear and tear)



Harmony Fit (30001096)

Floor mat – Ergonomic with anti-fatigue effect. For walking, standing and turning.

- Stimulates blood circulation
- Extremely elastic and hard-wearing
- Modern design, easy to clean, very long service life
- Mostly chemical and UV-resistant
- Grooved structure on the bottom surface prevents slipping on smooth floors
- Customised shapes and sizes available
- Chemical and UV-resistant

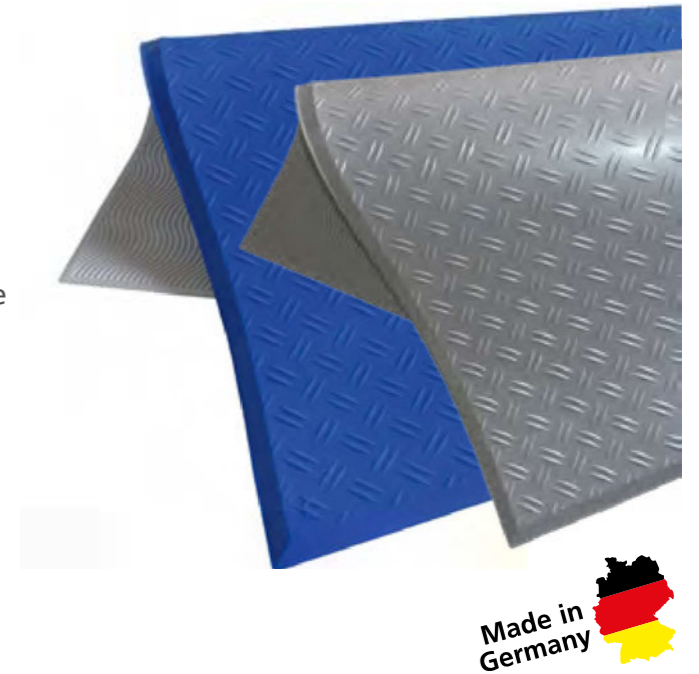

Features
Combines the advantages of a polyurethane mat with a very easy-to-clean and robust surface.

Application areas
Clean rooms, laboratories, order picking systems, retail, offices, banks, counters, etc.

Electrical resistance
10⁹ Ω antistatic/low charge

Features	
Material	Top layer of high-strength polyurethane film, high-quality foamed polyurethane
Surface	Ripple structure
Bottom surface	Groove wave structure, anti-slip
Colour	Silver, blue
Measurements	0,60 m x 0,90 m plus inclined approach (2,5 cm), custom sizes available
Height	ca. 11,5 mm
Weight	ca. 2,8 kg
Warranty	5 years (on material and workmanship with proper use, excluding wear and tear)

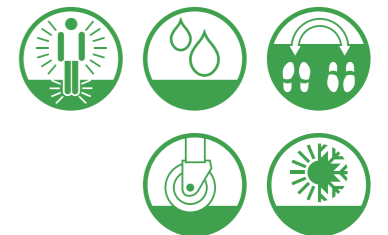

— Vario

Vario E (30001090)

Vario M (30001091)

Ergonomic nitrile floor mat

- Standing, walking and rotating workstations
- Can be extended as required (E/M)
- Quick assembly and disassembly

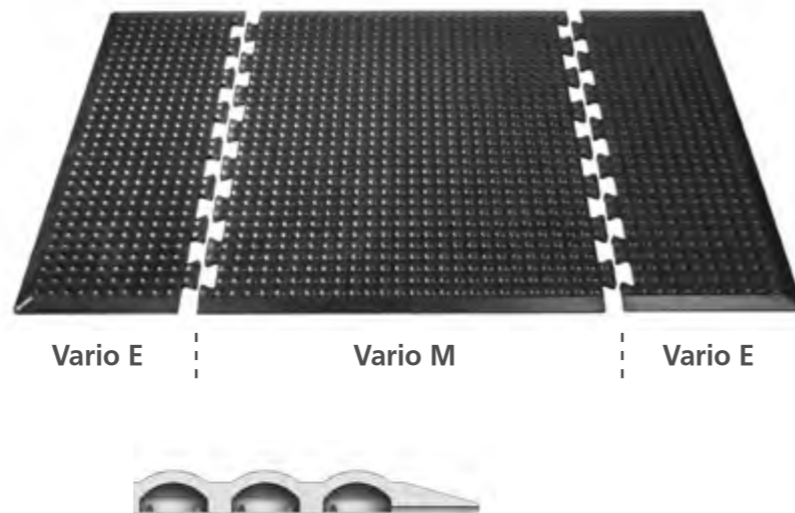

Features

Surefooted, anti-slip, resistant to hydrolysis, cold-insulating, shock-absorbing

Measurements

E = End piece ca. 79,5 x 27,5 cm
 M = Mid piece ca. 79,5 x 67,0 cm
 incl. inclined approach

Application areas

Lathes, milling machines, assembly, welding workplaces, workplaces with cold floors, etc. Not for oil or cooling lubricant areas.

Electrical resistance

$10^{12} \Omega$



Features	
Material	Natural rubber
Surface	Elasticated nub structure
Bottom surface	Hollow nubs
Colour	Black
Measurements	see features
Height	ca. 14 mm
Weight	E: ca. 2,4 kg M: ca. 5,6 kg
Warranty	2 years (on material and workmanship with proper use, excluding wear and tear)

— Legend

Icon explanation

- Slip-resistant, even on the floor mats bottom surface
- Ergonomically relieving
- Fire resistant DIN B1-4102-14
- Trafficable
- Resistant to oil, coolants and lubricants
- Drainage
- Rotating, workplaces with activities involving frequent rotating movements
- Suitable for wetness
- Heat/cold insulating
- Heat resistance up to 120° C
- ESD – electrostatic discharge to DIN EN 61340-5-1: 5 x 10⁷ Ω

— LongLife

- 58 – 59 Features
- 60 – 61 Tape goods versions
 - 62 LongLife tape goods
 - 63 LongLife tape goods: Hatched
 - 64 LongLife tape goods: ESD
 - 65 LongLife Floor strips
 - 66 LongLife Crosswalk stripes
 - 67 LongLife Symbols: Easy
 - 68 LongLife Symbols: Signs
 - 69 LongLife Clear window
- 70 – 71 LongLife Floor signs doorways
 - 72 LongLife Cutting device
 - 73 LongLife Cleaner
- 74 – 75 LongLife floor labeling signs
- 76 – 77 Services
- 78 – 81 myLinienlaser
- 82 – 85 mySpot LED-Projector
- 86 – 87 Service: myLean Floor markings

— Directly from the producer



ADHESIVE PROJECTING SPRAYING

LongLife floor markings – Suitable for the most extreme demands

myLean GmbH is a manufacturer of floor markings. myLean LongLife floor markings were developed in our own laboratory for the most extreme requirements. The floor markings are produced in our own production facility in Germany.

Whether for walkways, danger zones or storage areas, the right labelling increases work safety and makes it easier to comply with regulations. Correct labelling gives you a good overview of the availability of your goods, also with regard to stock reduction.

LongLife floor markings

Special features

myLean® floor markings can be used for almost all indoor surfaces. Our floor markings are self-adhesive and therefore quick and easy to apply. LongLife Floor markings from myLean are „forklift-proof“, even against turning on the marking.

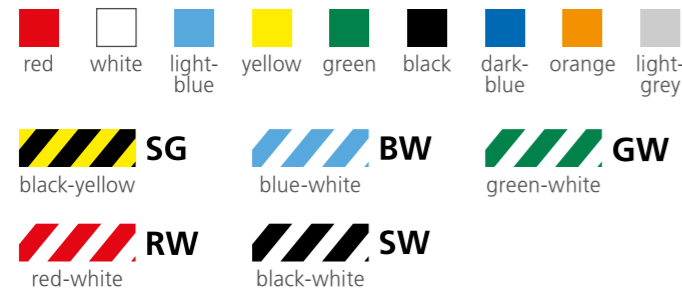

Imprintable



Transparent window, enables customised floor signage



Common 5S colours, formats and material thicknesses



Cutable



Self-adhesive, extremely adhesive on all surfaces, such as concrete, stone and metal



Forklift-proof, abrasion-resistant, extremely resilient, torsion-resistant

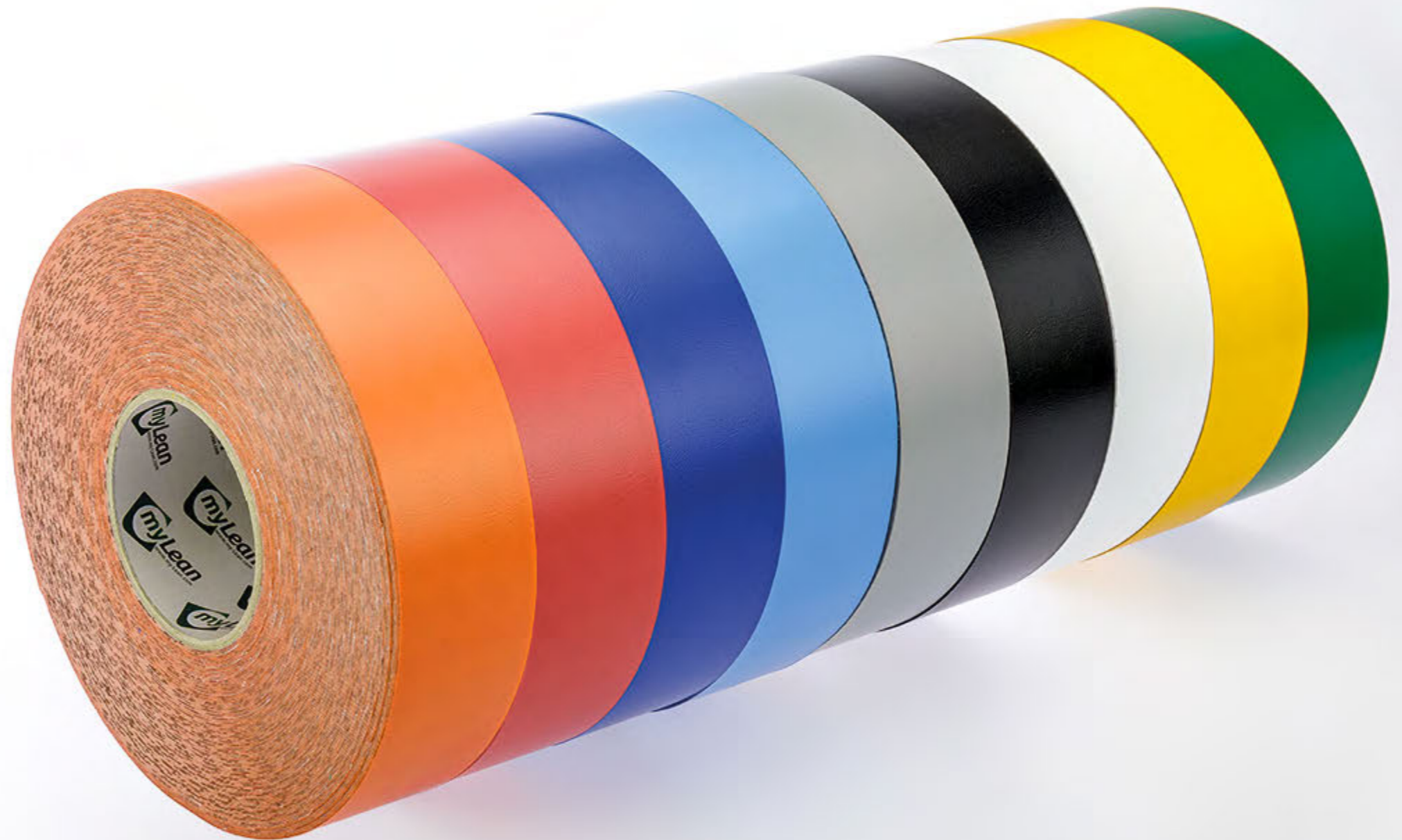

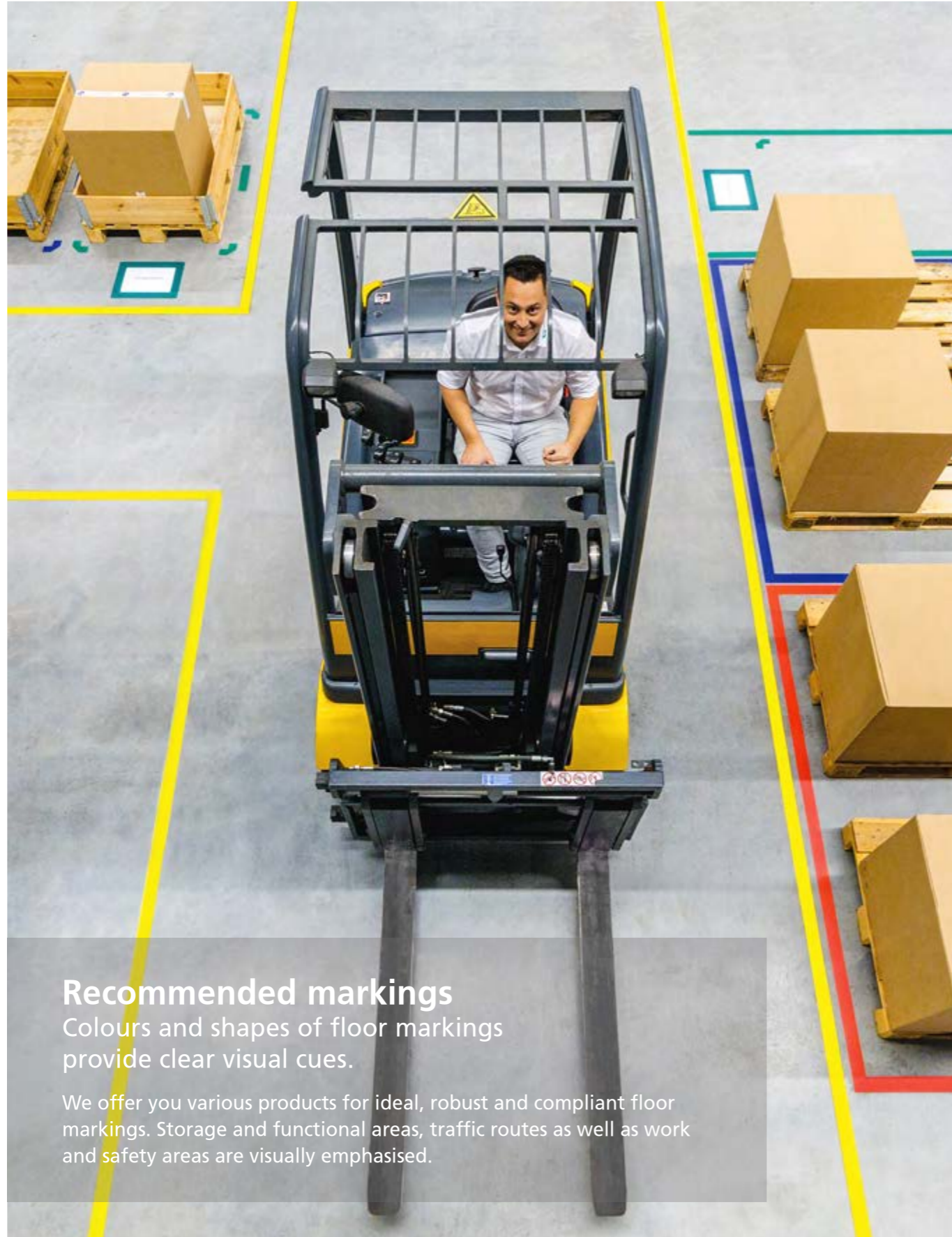







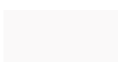

Recommended markings

Colours and shapes of floor markings provide clear visual cues.

We offer you various products for ideal, robust and compliant floor markings. Storage and functional areas, traffic routes as well as work and safety areas are visually emphasised.

Recommendation for colour coding

-  **Main and side routes**
Design: cut-to-size or strip goods
-  **Danger zones**
Design: cut-to-size or strip goods
-  **Raw material/delivery areas**
Design: cut-to-size or strip goods
-  **Other storage spaces**
Design: cut-to-size or strip goods
-  **Finished material/delivery area**
Design: cut-to-size or strip goods
-  **Empties**
Design: cut-to-size or strip goods
-  **Rejects/defective parts**
Design: cut-to-size or strip goods

-  **S51 Longitudinal markings**
Longitudinal markings clearly demarcate individual areas and help to structure your company. Clearly marked areas of drive-ways and walkways or storage and production areas and reduce the risk of accidents in companies. Clearly marked areas increase the efficiency of a company. Longitudinal markings in defined colour assignments are used to clearly separate areas from one another.
-  **Symbols**
Symbols are used to visualize and clearly assign areas, e.g. clearly marked storage areas minimize the risk of confusion and also increase the efficiency of your company. Symbols are used in defined colour assignments to clearly distinguish areas from one another.
-  **Mandatory signs**
Command signs improve occupational safety in your company and indicate how to behave in designated areas. The design is standardized in accordance with ASR A1.3 and draws employees' attention to hazards.
-  **Prohibition signs**
Prohibition signs prohibit certain actions in company areas and thus contribute to safety in companies. The design is standardized in accordance with ASR A1.3 and actively helps to prevent accidents at work.
-  **Warning and information signs**
Warning and information signs are standardized in accordance with ASR A1.3 and alert employees to hazards such as industrial trucks and highly flammable materials in designated areas.



LongLife tape goods | LongLife connection angle 45° & 90°

Our established and long-tested LongLife tape is extremely resistant to forklift trucks and abrasion. The backing material of our floor markings is dyed through, which prevents abrasion. The specially developed high-performance adhesive guarantees extreme adhesion on almost all indoor surfaces. Our 90° and 45° corners are prefabricated corner elements for creating corners on LongLife strip products. They are available in nine different standard colours.

- Common 55 colours
- Common 55 formats
- Self-adhesive
- Clear window, enables customised floor signage
- Can be cut to size
- Forklift-proof



LongLife tape goods	Width (mm)	Roll length (m)	Item-No. (+Colour code)	Colour = x	Roll*
	50	50 m	LL50-x	01 02 03 04 05 06 07 08 88	50 Meter
	75	50 m	LL75-x	01 02 03 04 05 06 07 08 88	50 Meter
	100	50 m	LL100-x	01 02 03 04 05 06 07 08 88	50 Meter

LongLife connection angle 45° & 90°	Description	Thigh (mm) Width/Length	Item-No. (+Colour code)	Colour = x	Pack*
	45 degree angle	50	LL-50-W45-x	01 02 03 04 05 06 07 08 88	50 pieces
	45 degree angle	75	LL-75-W45-x	01 02 03 04 05 06 07 08 88	50 pieces
	45 degree angle	100	LL-100-W45-x	01 02 03 04 05 06 07 08 88	50 pieces
	90 degree angle	50	LL-50-W90-x	01 02 03 04 05 06 07 08 88	50 pieces
	90 degree angle	75	LL-75-W90-x	01 02 03 04 05 06 07 08 88	50 pieces
	90 degree angle	100	LL-100-W90-x	01 02 03 04 05 06 07 08 88	50 pieces

*Prices, other dimensions and colours on request



LongLife tape goods hatched

Two-colour printed tape for demarcating different areas. Our two-colour hatched floor markings are self-adhesive and extremely durable against colour abrasion. Hatched tapes from our company are printed on the bottom surface, which prevents the colour from rubbing off. The adhesive properties of the two-colour tapes correspond to our proven LongLife quality. Hatched floor marking tapes are available in various colours and lengths.

- Common 55 colours
- Common 55 formats
- Self-adhesive
- Can be cut to size
- Forklift-proof



LongLife tape goods	Width (mm)	Roll length (m)	Item-No. (+Colour code)	Colour = x	Roll*
	50	25 m	LL50-x	SG BW GW RW SW	25 Meter
	75	25 m	LL75-x	SG BW GW RW SW	25 Meter
	100	25 m	LL100-x	SG BW GW RW SW	25 Meter

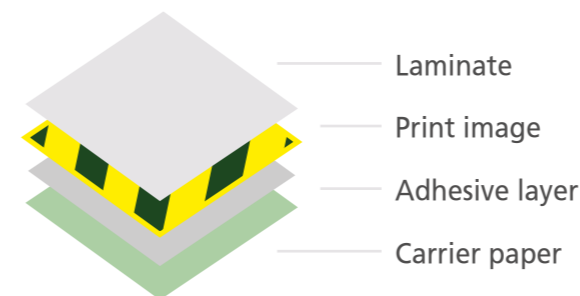

Layer structure material

The tape is printed on the reverse side. The colour application cannot be rubbed off the front, as it is protected by the film. A high-quality adhesive layer is used for LongLife floor markings.

Floor markings

— LongLife tape goods: ESD



LongLife tape goods ESD | customised | anti-slip

ESD

ESD Floor markings are self-adhesive and mark ESD areas. The ESD floor markings themselves are not conductive.

Customised

Customised floor markings are self-adhesive and are printed according to your specifications. Customised tapes from our company are printed on the bottom surface. This prevents abrasion of the colour.

Anti-slip

Anti-slip floor markings are self-adhesive and prevent any slipping thanks to their sanded surface. For use on steps or in machining operations with a lot of cooling lubricant.



LongLife tape goods ESD	Width (mm)	Roll length (m)	Item-No.
	50	5 m	LL50-ESD
	75	5 m	LL75-ESD
	100	5 m	LL100-ESD
LongLife tape goods customised	Width (mm)	Roll length (m)	Item-No.
	50	5 m	LL50-Customised
	75	5 m	LL75-Customised
	100	5 m	LL100-Customised
LongLife tape goods anti-slip	Width (mm)w	Roll length (m)	Item-No.
	50	18 m	LL50-Anti-slip
	75	18 m	LL75-Anti-slip
	100	18 m	LL100-Anti-slip

*Prices, other dimensions and colours on request

Floor markings

— LongLife Floor strips

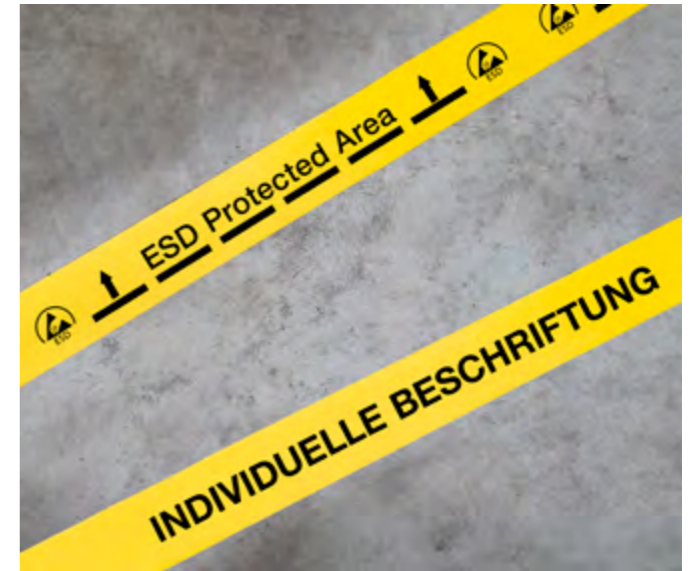

LongLife Floor strips

The LongLife floor strips offer an individual design, as texts and characters can be freely combined. They are available as strips or rolls and impress with their anti-slip properties, depending on the variant selected. They are also easy to clean, extra thin and particularly tear-resistant, making them ideal for a wide range of applications.

- 2 Lengths: 600 mm | 5000 mm
- Text as desired or template
- anti-slip & tear-resistant
- Self-adhesive
- Forklift-proof

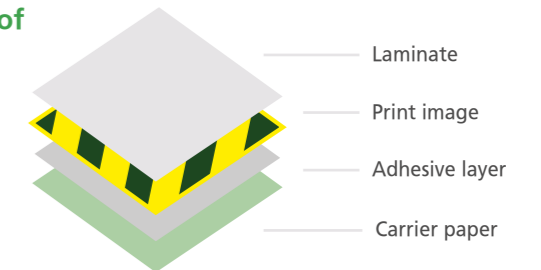

LongLife Floor strips Text as desired	Length	Item-No. 50 mm width	Item-No. 75 mm width	LongLife Floor strips ESD Protected Area	Length	Item-No. 50 mm width	Item-No. 75 mm width
	600 mm	LL50-600-Individuell	LL75-600-Individuell		600 mm	LL50-600-ESD	LL75-600-ESD
	5000 mm	LL50-5000-Individuell	LL75-5000-Individuell		5000 mm	LL50-5000-ESD	LL75-5000-ESD
LongLife Floor strips Attention forklift traffic	Length	Item-No. 50 mm width	Item-No. 75 mm width	LongLife Floor strips Attention step	Length	Item-No. 50 mm width	Item-No. 75 mm width
	600 mm	LL50-600-Staplerverkehr	LL75-600-Staplerverkehr		600 mm	LL50-600-Stufe	LL75-600-Stufe
	5000 mm	LL50-5000-Staplerverkehr	LL75-5000-Staplerverkehr		5000 mm	LL50-5000-Stufe	LL75-5000-Stufe
LongLife Floor strips Attention barrier	Length	Item-No. 50 mm width	Item-No. 75 mm width	LongLife Floor strips No entry	Length	Item-No. 50 mm width	Item-No. 75 mm width
	600 mm	LL50-600-Schranke	LL75-600-Schranke		600 mm	LL50-600-Zutritt	LL75-600-Zutritt
	5000 mm	LL50-5000-Schranke	LL75-5000-Schranke		5000 mm	LL50-5000-Zutritt	LL75-5000-Zutritt

Floor markings

— LongLife Crosswalk stripes



LongLife Crosswalk stripes

The LongLife crosswalk floor markings impress with their resilience and flexibility for a wide range of applications. They ensure clear and safe pedestrian guidance, increase traffic safety and prevent accidents in busy areas. By using LongLife crosswalks, you increase both the safety standards and the work processes in your company.

- Common 55 colours
- Common 55 formats
- Self-adhesive
- Forklift-proof
- Can be cut to size

VE = 1 piece



LongLife Crosswalk stripes	Length (mm)	Width (mm)	Item-No. (+Colour code)	Colour = x [Red][White][Blue][Yellow][Green][Black][Orange][Grey]
	1200 mm	200 mm	LLZS-120-x	01 02 03 04 05 06 07 08 88
	1500 mm	300 mm	LLZS-150-x	01 02 03 04 05 06 07 08 88

Floor markings

— LongLife Symbols: Easy

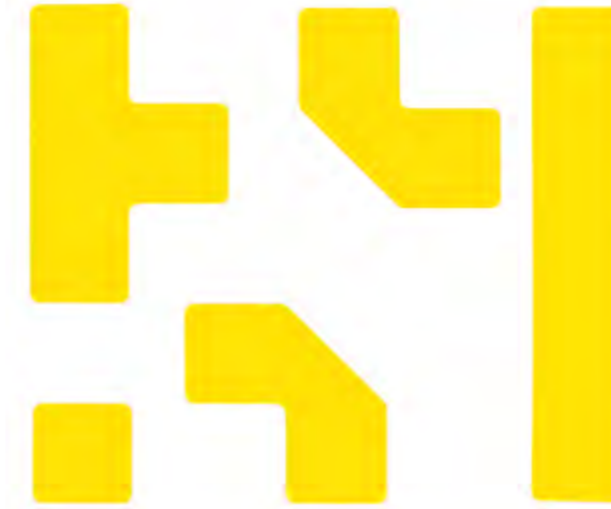

LongLife Symbols Easy

LongLife symbols are self-adhesive and are used to mark parking spaces, storage areas, transportation routes, etc. Our LongLife Symbols are available in nine different standard colours. Depending on the application, longitudinal markings, T-pieces, L-angles, dots or crosses are used.

- Common 55 colours
- Common 55 formats
- Self-adhesive
- Forklift-proof

VE = 50 pieces



LongLife Symbols	Description	Thigh (mm) Width/Length	Item-No. (+Colour code)	Colour = x [Red][White][Blue][Yellow][Green][Black][Orange][Grey]	Pack*
	T-pieces	50	LL-50-T-x	01 02 03 04 05 06 07 08 88	50 pieces
	T-pieces	75	LL-75-T-x	01 02 03 04 05 06 07 08 88	50 pieces
	L-Angle	50	LL-50-L-x	01 02 03 04 05 06 07 08 88	50 pieces
	L-Angle	75	LL-75-L-x	01 02 03 04 05 06 07 08 88	50 pieces
	Longitudinal mark.	50/250	LL-50250-x	01 02 03 04 05 06 07 08 88	50 pieces
	Longitudinal mark.	75/350	LL-75350-x	01 02 03 04 05 06 07 08 88	50 pieces
	Longitudinal mark.	100/500	LL-100500-x	01 02 03 04 05 06 07 08 88	50 pieces
	Square	50	LL-50-Q-x	01 02 03 04 05 06 07 08 88	50 pieces
	Square	75	LL-75-Q-x	01 02 03 04 05 06 07 08 88	50 pieces
	Square	100	LL-100-Q-x	01 02 03 04 05 06 07 08 88	50 pieces

*Prices, other dimensions and colours on request



LongLife Symbols Feet, arrows, letters and numbers

LongLife symbols feet, arrows, letters and numbers are self-adhesive and serve as directional signs and for visualizing footpaths and driveways. Feet, arrows, letters and numbers are available in nine different colours and correspond to our LongLife quality.



LongLife Symbols feet & arrows	Description	Width (mm)	Length (mm)	Item-No. (+Colour code)	Colour = x	Pack*
	Foot	90	280	LLSTP-x	01 02 03 04 05 06 07 08 88	50 pieces
	Arrow	100	175	LLPF-x	01 02 03 04 05 06 07 08 88	50 pieces

LongLife Symbols letters & numbers	Description	Total-Height (cm)	Item-No. (+letter/number +Colour code)	Colour = x	Pack*
A **	Letter	10	LLB10-_-x	01 02 03 04 05 06 07 08 88	10 pieces
	Letter	15	LLB15-_-x	01 02 03 04 05 06 07 08 88	10 pieces
	Letter	20	LLB20-_-x	01 02 03 04 05 06 07 08 88	10 pieces
2 **	Number	10	LLZ10-_-x	01 02 03 04 05 06 07 08 88	10 pieces
	Number	15	LLZ15-_-x	01 02 03 04 05 06 07 08 88	10 pieces
	Number	20	LLZ20-_-x	01 02 03 04 05 06 07 08 88	10 pieces

**Letters: A-Z, numbers: 0-9 available

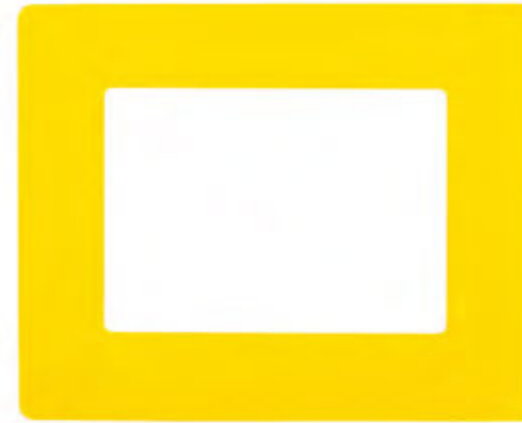

LongLife Clear window

Our floor windows are used to attach printed documents to the floor, allowing areas to be marked. LongLife floor windows are self-adhesive and available in various colours and sizes. It is also possible to apply barcodes with our floor windows. A special anti-reflective surface structure enables error-free scanning.

- Imprintable
- Self-adhesive
- Common 5S colours
- Common 5S formats
- Forklift-proof



LongLife Clear window	Description	Width (mm)	Length (mm)	Item-No. (+Colour code)	Colour = x	Pack*
	DIN A4	400	310	LL-KL-A4-x	01 02 03 04 05 06 07 08 88	10 pieces
	1/2 DIN A4	400	205	LL-KL-1/2A4-x	01 02 03 04 05 06 07 08 88	10 pieces
	DIN A5	310	250	LL-KL-A5-x	01 02 03 04 05 06 07 08 88	10 pieces
	1/3 DIN	310	200	LL-KL-1/3DIN-x	01 02 03 04 05 06 07 08 88	10 pieces

*Prices, other dimensions and colours on request

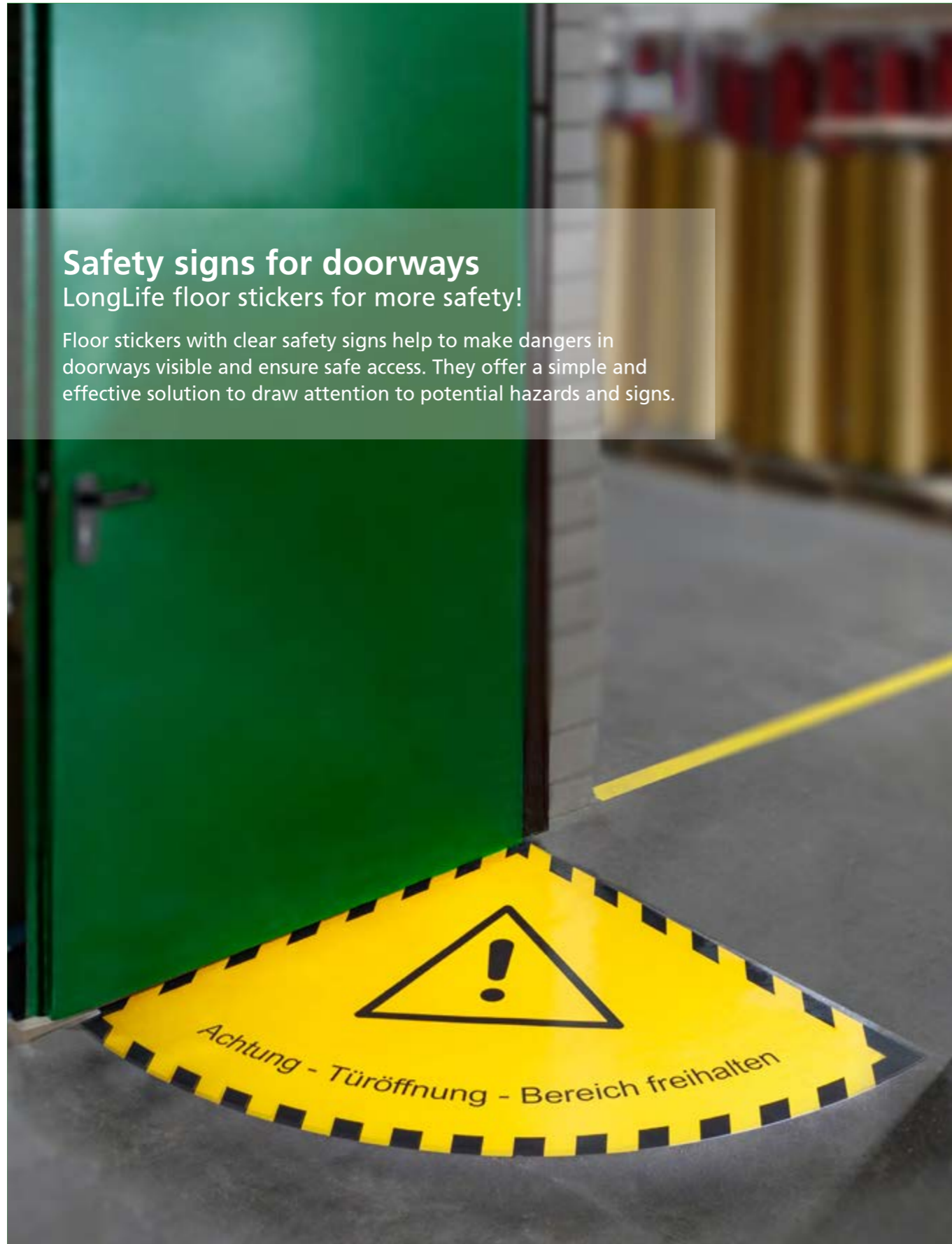

Safety signs for doorways

LongLife floor stickers for more safety!

Floor stickers with clear safety signs help to make dangers in doorways visible and ensure safe access. They offer a simple and effective solution to draw attention to potential hazards and signs.

LongLife Floor signs doorways

The LongLife floor signs for doorways ensure greater safety by clearly marking danger zones. Thanks to their high visibility and non-slip surface, they provide effective orientation for employees and visitors. They are durable, easy to apply and ideal for industry, warehouses or public buildings. In this way, they actively contribute to accident prevention and safe access.

- Imprintable
- Self-adhesive
- Text as desired or template
- Common 5S colours
- Common 5S formats
- Forklift-proof

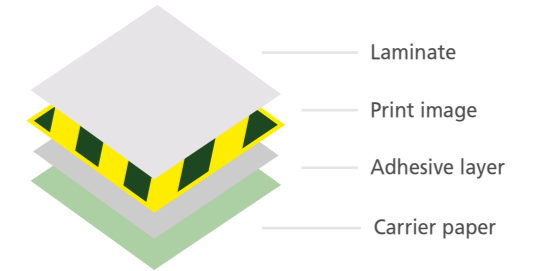

VE = 1 piece



LongLife Floor signs Fire extinguisher (half circle)	Height x width	Item-No.	LongLife Floor signs Foot protection (half circle)	Height x width	Item-No.
	750 x 375 mm	LL-Schild1/2-750-1		750 x 375 mm	LL-Schild1/2-750-10
	900 x 450 mm	LL-Schild1/2-900-1		900 x 450 mm	LL-Schild1/2-900-10
LongLife Floor signs Warning sign (half circle)	Height x width	Item-No.	LongLife Floor signs Escape route (half circle)	Height x width	Item-No.
	750 x 375 mm	LL-Schild1/2-750-7		750 x 375 mm	LL-Schild1/2-750-6
	900 x 450 mm	LL-Schild1/2-900-7		900 x 450 mm	LL-Schild1/2-900-6
LongLife Floor signs Fire extinguisher (quarter circle)	Height x width	Item-No.	LongLife Floor signs Foot protection (quarter circle)	Height x width	Item-No.
	750 x 750 mm	LL-Schild1/4-750-1		750 x 750 mm	LL-Schild1/4-750-10
	900 x 900 mm	LL-Schild1/4-900-1		900 x 900 mm	LL-Schild1/4-900-10
LongLife Floor signs Warning sign (quarter circle)	Height x width	Item-No.	LongLife Floor signs Escape route (quarter circle)	Height x width	Item-No.
	750 x 750 mm	LL-Schild1/4-750-7		750 x 750 mm	LL-Schild1/4-750-6
	900 x 900 mm	LL-Schild1/4-900-7		900 x 900 mm	LL-Schild1/4-900-6

Floor markings

— LongLife Cutting device



LongLife Cutting device

Our LongLife cutting device helps you to cut our LongLife strip goods precisely to length and to mitre cut them skilfully. Cutting takes place inside the device, which prevents injuries. The clamping effect prevents the hinges from slipping.

- Angle 90°
- Angle 45° double-sided
- Suitable for all widths: 50/70/100 mm of our LongLife Floor markings

LongLife Cutting device	Height (mm)	Width (mm)	Length (mm)	Item-No.	Pack*
	3	112	260	LL-AV100	1 piece

*Prices, other dimensions and colours on request

Floor markings

— LongLife Cleaner



LongLife Cleaner

Before applying the LongLife floor marking make sure that your floor is free of dust, oil and dirt. To ensure this, we recommend our LongLife Cleaner. Our LongLife Cleaner is environmentally friendly and pH-neutral. For convenient use, it can simply cleaning machines, high-pressure cleaners or steam cleaners for convenient use. The floor must be dry before applying the LongLife floor marking.

- pH neutral
- Biodegradable
- Odourless
- Environmentally friendly
- No VOCs
- Water soluble

LongLife Cleaner	Contents	Item-No.	Colour code
	2 L canister	30001313	1 Canister

LongLife Floor labeling sings

Information signs, prohibition signs, warning and mandatory signs

Our LongLife floor identification signs are self-adhesive and can be driven over. They are printed from the bottom surface, which prevents the colour abrasion of the colour. The warning and effect of the bottom labelling signs the work safety is significantly increased.

- Self-adhesive
- Forklift suitable
- High warning & information effect
- More symbols on request



LongLife Information signs*	Description	Diameter (mm)	Item-No.	Pieces*
	Warning of forklift trucks	600	LL-Schild-600-9	1 piece
	Warning of obstacles on the floor	600	LL-Schild-600-10	1 piece
	General warning sign	600	LL-Schild-600-20	1 piece
	Warning Danger of slipping	600	LL-Schild-600-26	1 piece
	Warning of toxic substances	600	LL-Schild-600-12	1 piece

LongLife Prohibition signs*	Description	Diameter (mm)	Item-No.	Pieces*
	No smoking	600	LL-Schild-600-21	1 piece
	No forklift trucks	600	LL-Schild-600-23	1 piece
	No parking or storage allowed	600	LL-Schild-600-7	1 piece
	Forbidden for pedestrians	600	LL-Schild-600-22	1 piece
	No access for unauthorised persons	600	LL-Schild-600-27	1 piece

*Conform to standards and regulations in accordance with ASR A1.3. We can produce other symbols on request.

LongLife Mandatory signs*	Description	Diameter (mm)	Item-No.	Pieces*
	Use mask	600	LL-Schild-600-1	1 piece
	Use head protection	600	LL-Schild-600-2	1 piece
	Wear hearing protection	600	LL-Schild-600-15	1 piece
	Use eye protection	600	LL-Schild-600-14	1 piece
	Wear a safety waistcoat	600	LL-Schild-600-32	1 piece
	Use foot protection	600	LL-Schild-600-28	1 piece
	For pedestrians	600	LL-Schild-600-29	1 piece
	Wear gloves	600	LL-Schild-600-30	1 piece
	Wear a protective suit	600	LL-Schild-600-31	1 piece



Fire safety and escape signs on request

*Prices, other dimensions and colours on request.
More symbols on request

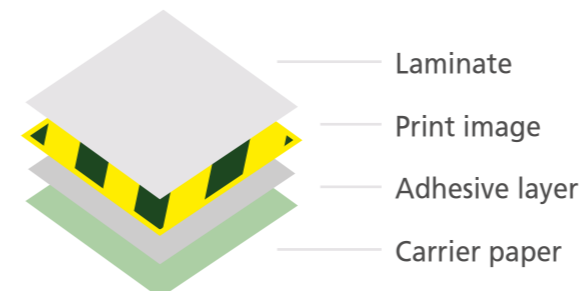

Layer structure material

The tape is printed on the reverse side. The colour application cannot be rubbed off the front, as it is protected by the film. A high-quality adhesive layer is used for LongLife Floor markings.



Have it labelled by an expert!

LongLife Floor markings professionally installed

We are also happy to act as a service provider for you. Whether vehicles, zebra crossings, parking spaces, etc. Have your floor markings professionally installed by our specialist staff. Contact us, we will find the optimum solution for everyone.

Contact

Tel. 07024 466 27 0 | info@my-lean.com

Clean surface
Use the LongLife Cleaner to clean the surface residue-free of adhesive residues, dirt, grease and oil. Ideal application temperature 18° to 25° C. Cure for approx. 12 – 24 hours.

Align labelling
Pre-mark/project the line on dry ground using chalk/laser. Maintain a minimum distance of 30 – 50 mm around the object to be labelled. Avoid overlapping the floor markings.



Perfect features
LongLife Tape goods and transparent windows adhere perfectly to any surface: Concrete, stone or metal are extremely resilient and torsion-resistant.

Attach floor markings
Peel off the protective film piece by piece and press on firmly. Apply as tape goods. Cut off the film at the end. Angles (45°/90°) and special cuts safely and accurately with the LongLife cutting device.

myLinienlaser

Abrasion-resistant path and floor marking using highly visible laser lines – efficiency and safety for your production facilities.



myLinienlaser project virtual floor markings onto industrial floors, in warehouses or other buildings. The laser unit is mounted overhead on a hall ceiling or wall and draws a clearly visible, wide line of light on the floor.

Technical data

- **Size (mm)**
 - Mount ca. 150 x 120 x 65 mm
 - Laser ca. 18 x 100 mm
- **Service life** > 40.000 h
- **Power input** < 8 W
- **Temperature range** -30 °C to + 45 °C
- **Power supply** 24 VDC, 100-240 VAC
- **Operating time** 24/7, without limitation
- **Mount** 3 axes adjustable
- **Installation** Magnetic base/ screwing device/ adapter for conductor rail
- **Laser-/Line colours** red green, light blue
- **Performance** 300 mW, 750 mW, 1000 mW
- **Line angle optics** 30° degree up to 110° degree optical angle
- **Line length** 0,5 m up to 20 m Flexible and precisely adjustable
- **Line width** 3 – 6 cm (depending on installation height)
- **Laserclass** Laserclass 2 (after installation)



Accessories

Line length limiter*	Maximum angle	Item-No.	Magnetic holder	Magnet size Ø	Item-No.
	60° Degree or less	30003025		60 mm	30003040
	90° Degree or less	30003041			

*The line length limiter is clamped onto the laser module and can be rotated.





Precise & long-lasting markings – Safety with the myLinienlaser!

A myLinienlaser ensures precise and permanent marking of walkways, driveways, stop lines or danger zones – even in very dusty and dirty environments. Thanks to its high abrasion resistance, the marking remains safe and clearly visible. Different areas can be clearly demarcated by selecting different colors. This creates a structured and safe working environment with optimum orientation.



myLinienlaser red	Performance	Angle	Item-No.
	300 mW	60° Degree	30003045
	300 mW	90° Degree	30003047
	800 mW	60° Degree	30003037
	800 mW	90° Degree	30003039

myLinienlaser green	Performance	Angle	Item-No.	myLinienlaser light blue	Performance	Angle	Item-No.
	300 mW	60° Degree	30003053		1000 mW	60° Degree	30003027
	300 mW	90° Degree	30003055		1000 mW	90° Degree	30003029
	750 mW	60° Degree	30003077				
	750 mW	90° Degree	30003079				

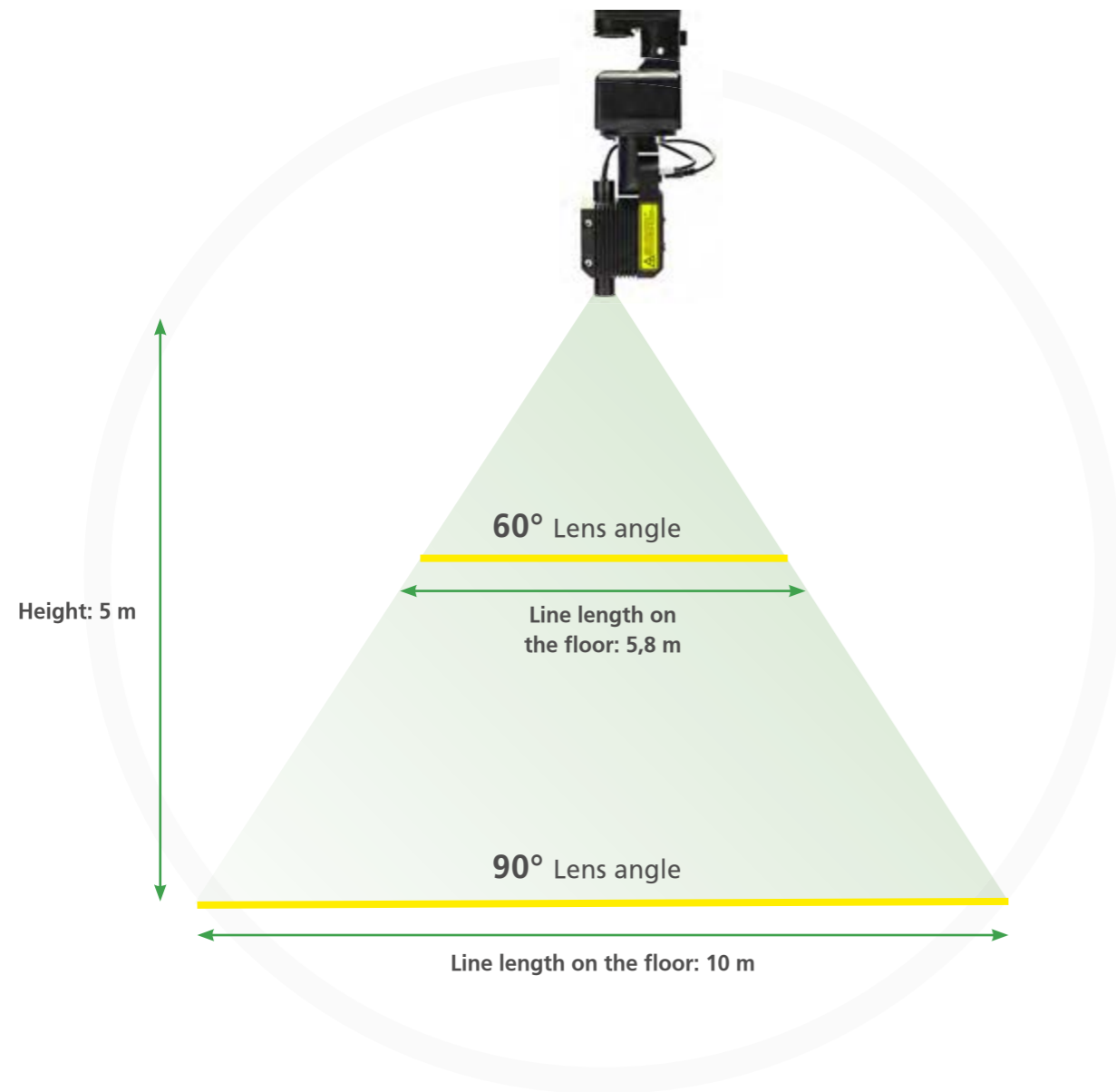

Danger warning

The top priority when using line lasers in the commercial sector is laser safety for users and observers. myLine lasers are considered "extended sources" according to TROS and require fewer safety measures than point lasers. The necessary safety distance depends on the deflection angle: the greater the angle, the shorter the distance. The laser color is irrelevant as long as the laser is visible. A table supplied with the laser indicates the minimum distances required to comply with laser safety class 2.

An example illustrates the requirements: With a laser power of 750 mW and a deflection angle of 90°, the safety distance is 1300 mm. Add to this 2000 mm for the viewing size, which results in a minimum mounting height of 3320 mm in relation to the laser exit. In many cases, a detailed analysis of the final installation may allow shorter distances. A specific risk assessment can also contribute to safety. For a more precise classification, a detailed inspection should be carried out on the respective laser installation.

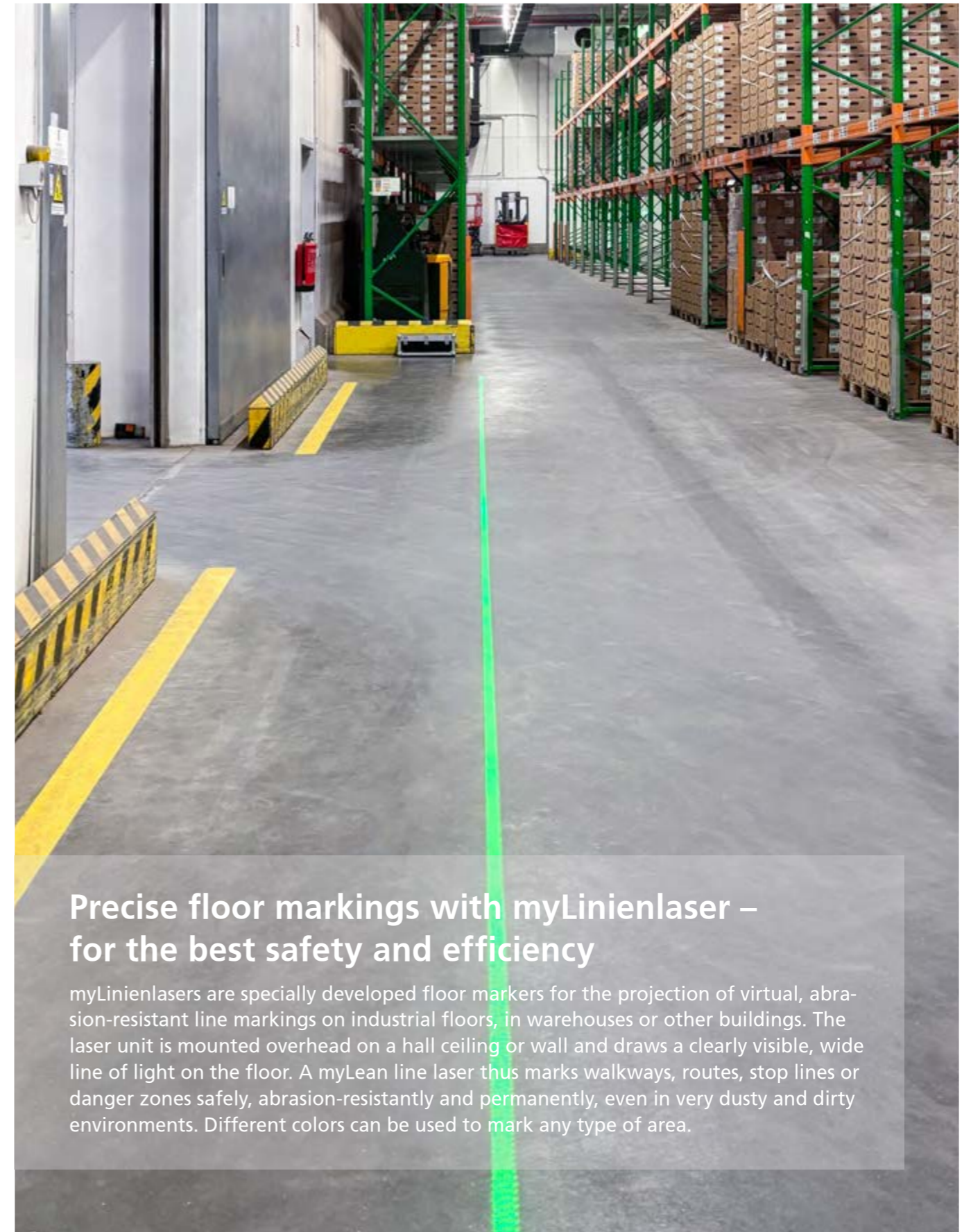

Precise floor markings with myLinienlaser – for the best safety and efficiency

myLinienlasers are specially developed floor markers for the projection of virtual, abrasion-resistant line markings on industrial floors, in warehouses or other buildings. The laser unit is mounted overhead on a hall ceiling or wall and draws a clearly visible, wide line of light on the floor. A myLean line laser thus marks walkways, routes, stop lines or danger zones safely, abrasion-resistently and permanently, even in very dusty and dirty environments. Different colors can be used to mark any type of area.

mySpot LED-Projector

The ultimate solution for signage in challenging environments!

- Projection of still and rotating images
- Abrasion-resistant for long-lasting use
- High-power LED in high definition
- Variety of applications
- Dustproof and protected against moisture
- 360° rotating lens with switch
- Robust and durable wall bracket
- Easily interchangeable motifs
- High energy efficiency

Technical data

- | | |
|----------------------|-------------------|
| • Protection class | IP65 |
| • Lifetime | 25.000 h |
| • Dimensions (mm) | 260 x 180 x 150 |
| • LED type | COB |
| • Colour | black |
| • Material | metal |
| • Colour temperature | cool white |
| • Nominal voltage | 230 Volt AC |
| • Luminosity | 40 Watt |
| • Light flux | 4.000 lm |
| • Kelvin | 6.000 K |
| • Temperature range | -18 °C to + 55 °C |
| • Outdoor use | Yes |

Item-No. 30004423

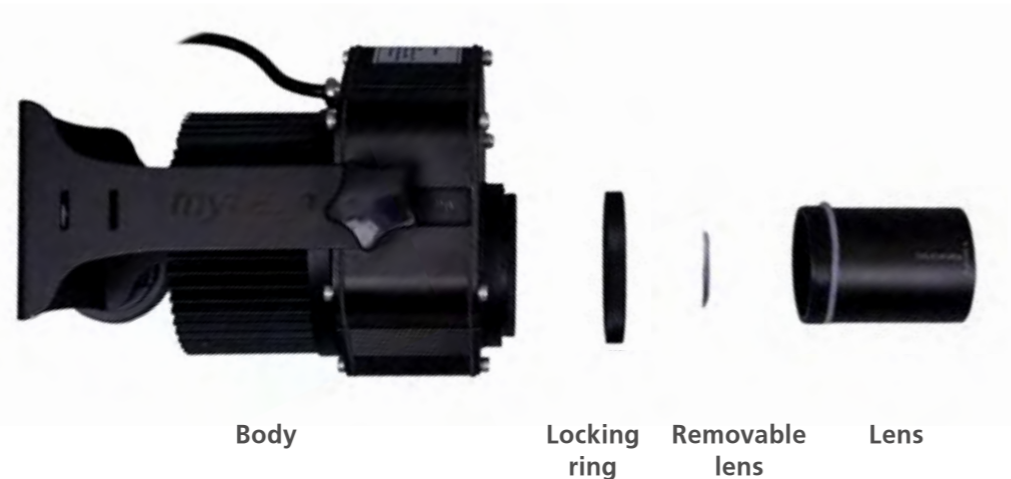

Body

Locking ring

Removable lens

Lens



Master poor lighting conditions in a modern way with LED technology.

Discover the revolutionary solution for signage in hard-to-reach areas. The mySpot is designed to illuminate areas where conventional signs cannot be installed. Thanks to its powerful light source and interchangeable lenses, it maximises impact and adaptability. Thanks to the 360° rotating lens (via switch), it offers the possibility of making the symbol recognisable from all directions. Upgrade your production with our LED projector and create an efficient wayfinding system.

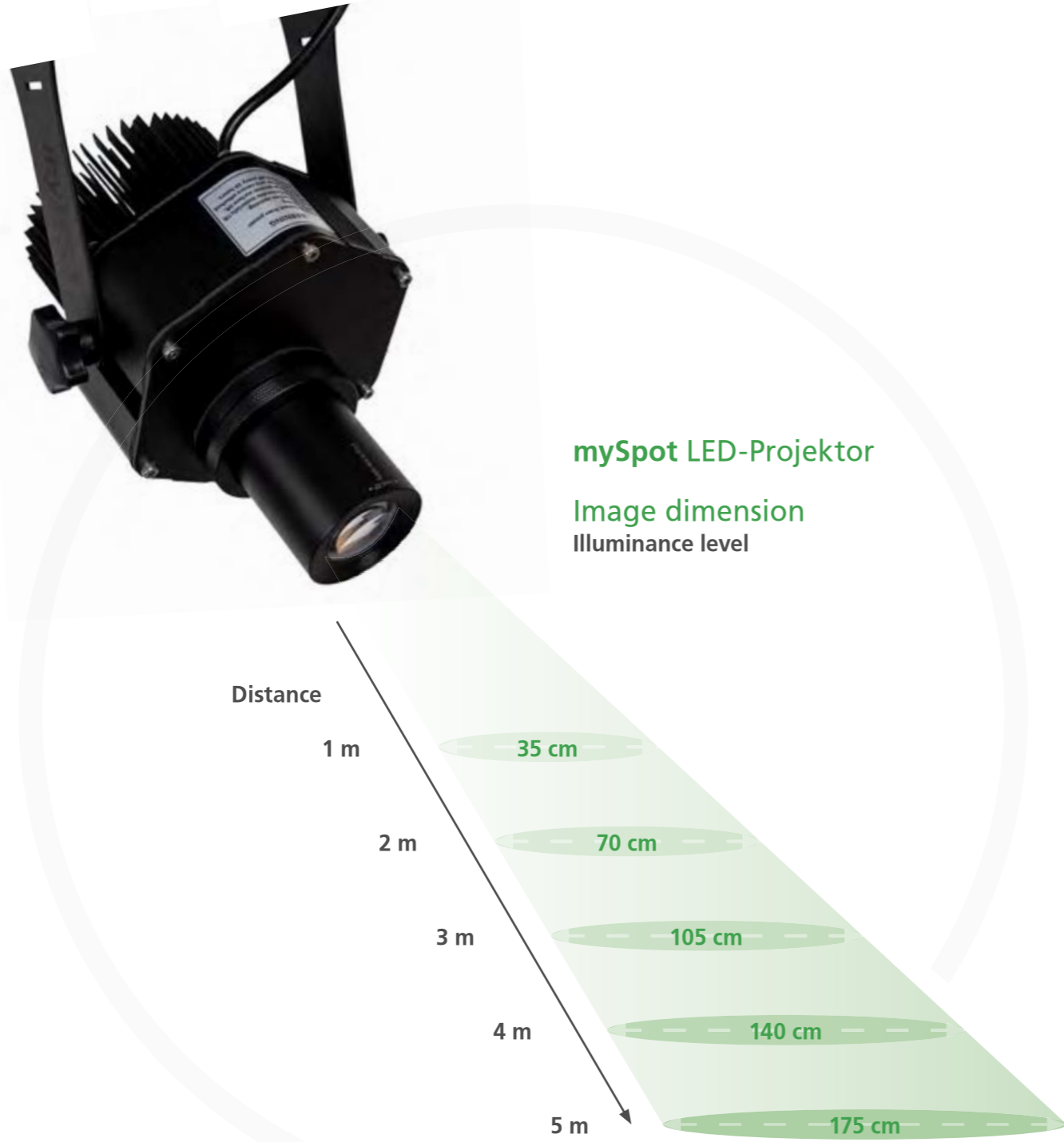

Interchangeable lens designs

Lens designs individually printed according to your wishes

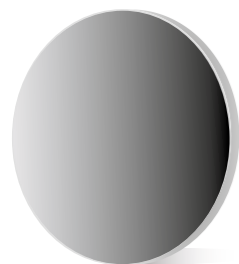

single-coloured

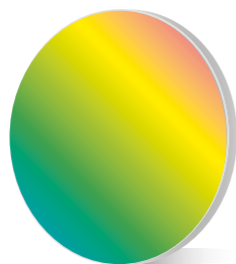

multi-coloured



Interchangeable lens designs

Lens designs	Description	Item-No.	Quantity
	Use head protection	30003005	1 piece
	Wear hearing protection	30003006	1 piece
	Use eye protection	30003007	1 piece
	Wear a safety waistcoat	30003008	1 piece
	Use foot protection	30003009	1 piece
	For pedestrians	30003010	1 piece
	Warning of forklift trucks	30003011	1 piece
	Warning of obstacles on the floor	30003012	1 piece
	General warning sign	30003013	1 piece
	Warning Danger of slipping	30003014	1 piece
	Warning of toxic substances	30003015	1 piece
	No smoking	30003016	1 piece
	No forklift trucks	30003017	1 piece
	No parking or storage allowed	30003018	1 piece
	Forbidden for pedestrians	30003019	1 piece
	No access for unauthorised persons	30003020	1 piece

Many other mandatory signs, information signs and prohibition signs on request.

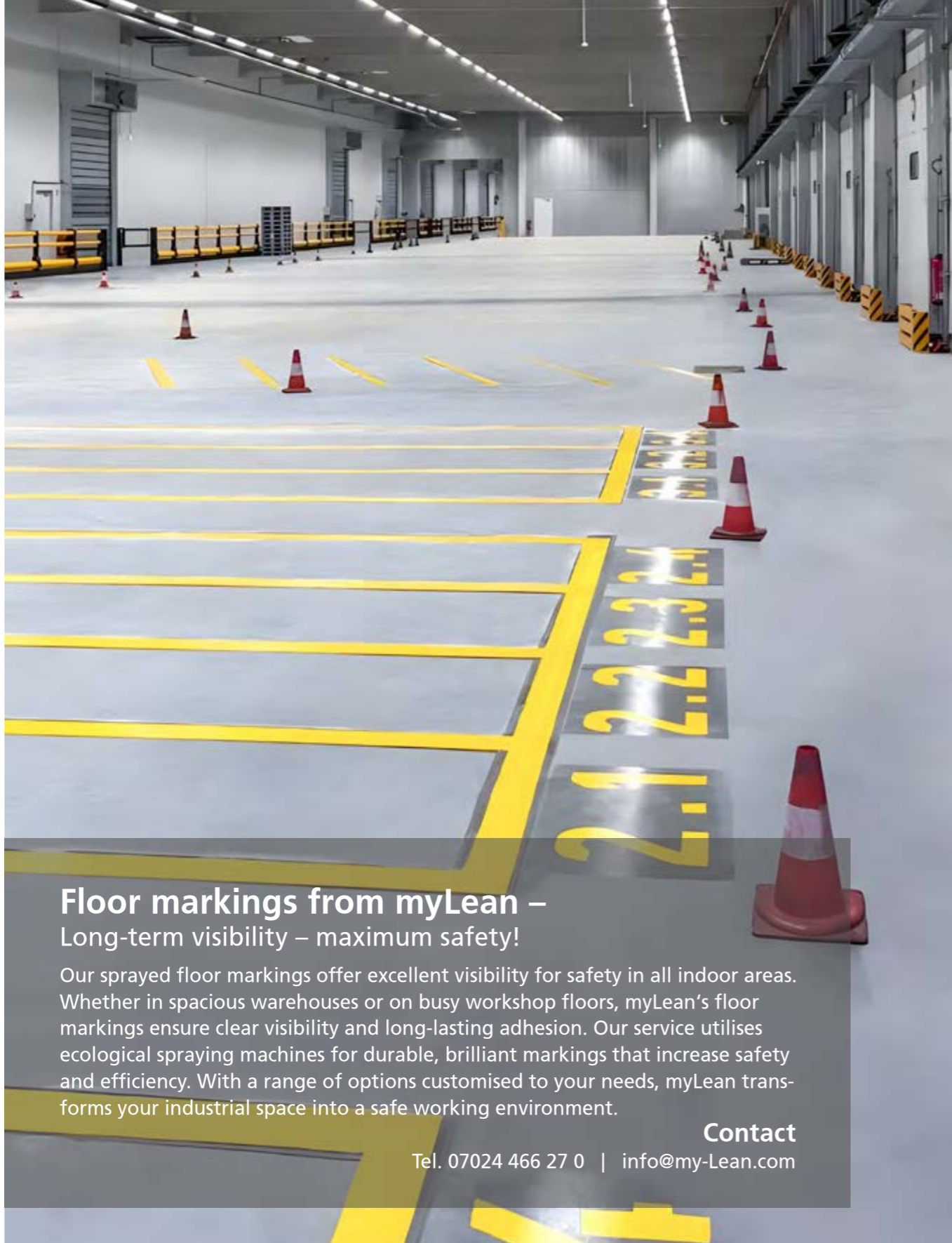

Floor markings from myLean – Long-term visibility – maximum safety!

Our sprayed floor markings offer excellent visibility for safety in all indoor areas. Whether in spacious warehouses or on busy workshop floors, myLean's floor markings ensure clear visibility and long-lasting adhesion. Our service utilises ecological spraying machines for durable, brilliant markings that increase safety and efficiency. With a range of options customised to your needs, myLean transforms your industrial space into a safe working environment.

Contact

Tel. 07024 466 27 0 | info@my-Lean.com



Customised sprayed floor markings from myLean for especially high requirements!

Logistics centres, warehouses and industrial halls are places that are frequented by a large number of road users. To ensure the safety of these environments, it is essential that traffic routes are marked with clearly visible colours. Thanks to their low susceptibility to dirt and an anti-slip surface, our sprayed floor markings ensure a perfect result.

Features

- All traffic colours
- Extremely resilient
- Scratch and impact resistant – extreme floor adhesion
- UV and weather resistant
- Epoxy modified HS paint (1 K & 2 K material)
- Polyurethane paint
- Thick film material: cold plastic & thermoplastic

Service process:

- Contact by customers to discuss the detailed enquiry.
- Assessment and recording of the spatial conditions.
- Based on the information gathered, technical advice can be provided at the customer's request.
- Based on the assessment myLean prepares a detailed offer.

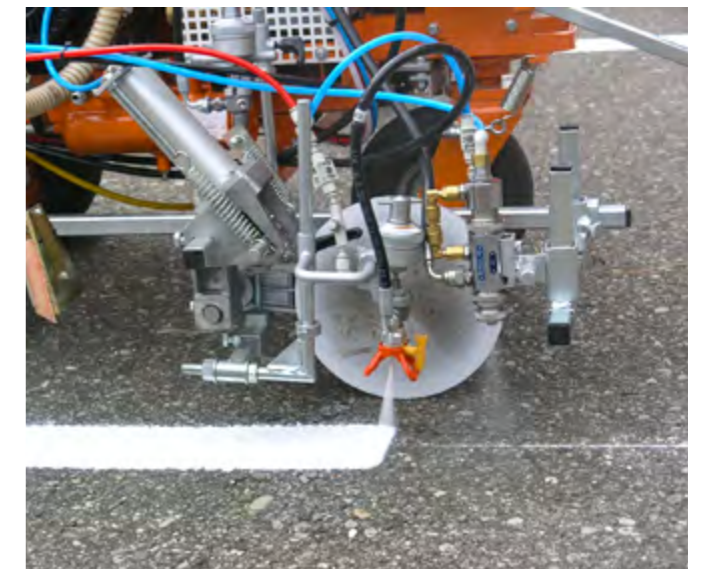

— Space-saving and cleverly organised

- 90 General information
- 91 Poster frames
- 92 Pallet stand
- 93 – 98 Accessories
- 99 List holder
- 100 – 101 Custom business signage

— Signage with a system



Visualise and labeling in all areas of the company

The robust and easy-to-use frames allow you to identify storage spaces, storage locations, workstations and shelves and are ideal for use as a visualisation tool and information exchange material. Thanks to the large selection of accessories, you can customise all areas of your company.

Poster frames structure

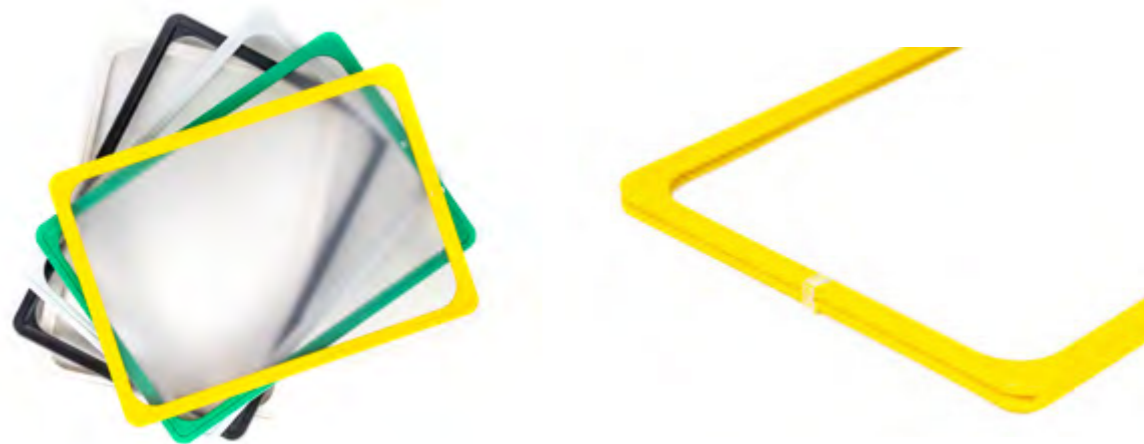
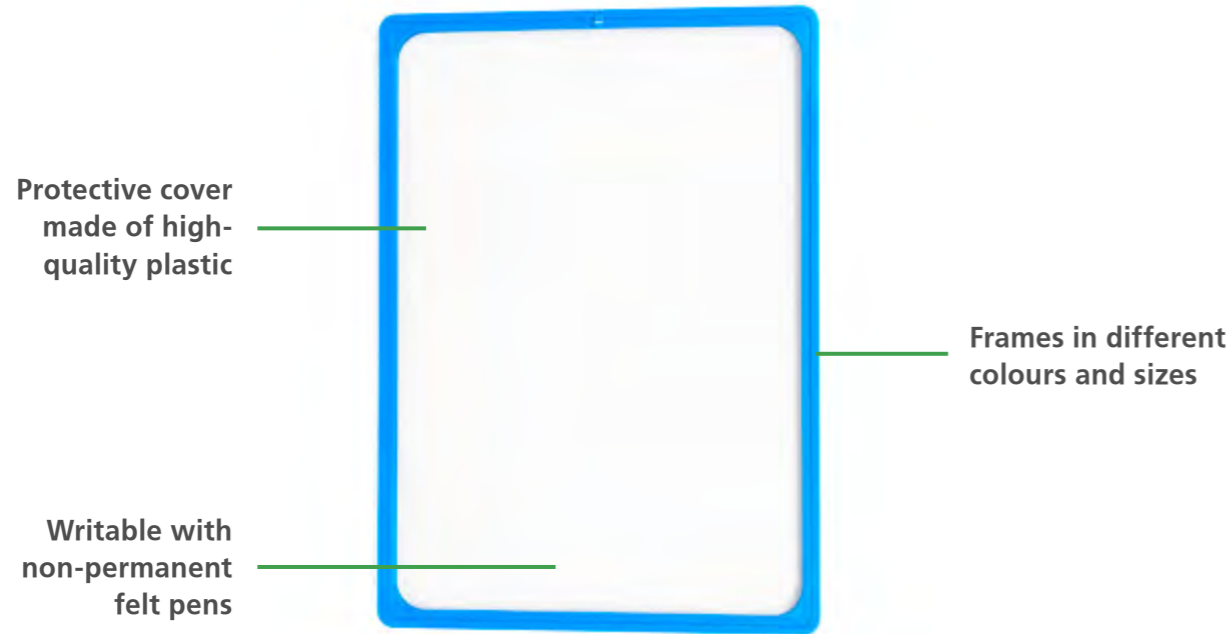

Various colours

Plastic frame



Locking clips



High-quality material

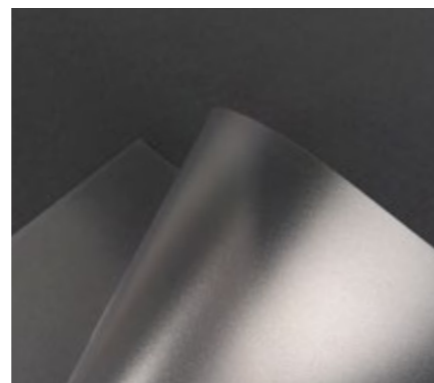

Protective sleeve



Poster frames

The poster frames are available in sizes from DIN A5 to DIN A1 and in 8 different colours. They can be used in both portrait and landscape format. Transparent protective cover with anti-reflective surface and fastening clip included.

VE = 10 pieces



Item-No. Din A1	Item-No. Din A2	Item-No. Din A3	Item-No. Din A4	Item-No. Din A5	Colour	Colour name
10002010	10002020	10002030	10002040	10002050		green
10002011	10002021	10002031	10002041	10002051		red
10002012	10002022	10002032	10002042	10002052		light-blue RAL 5015
10002013	10002023	10002033	10002043	10002053		yellow
10002014	10002024	10002034	10002044	10002054		white
10002015	10002025	10002035	10002045	10002055		black
10002016	10002026	10002036	10002046	10002056		grey
10002017	10002027	10002037	10002047	10002057		light-grey
10002557	10002556	10002552	10002554	10002555		dark-blue RAL 5002



Pallet stand

- Robust and durable pallet stand made of aluminium or steel for absolute stability: poster frame capacity – DIN A5 to DIN A
- Practical click mechanism for easy replacement of boards
- Poster frame is not part of the article. This must be purchased separately.

VE = 1 piece



Features		
Size	telescopic 150 – 225 cm	Base plate Ø 255 mm telescopic 80-160 cm with locking lever
Material	Aluminium	Chromed standpipe
Colour	black	silver-grey
Contents	1 Jumbo-base plate, 1 Alu-telescopic pipe, 150 cm length 1 Super-G-adapter Screws, adhesive pad and instruction manual	1 Base plate 1 Aluminium telescopic pipe 1 Adapter
Application	Pallet stands for plastic frames for attaching posters to pallets	Pallet stands for plastic frames for attaching posters to pallets
Item-No.	10002062	10002164

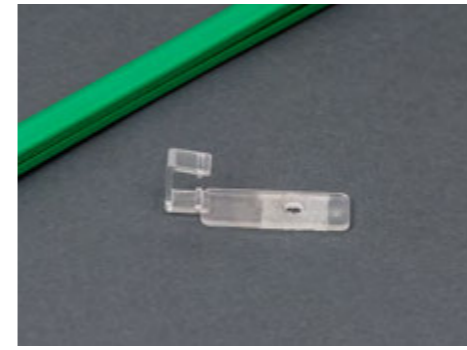

Frame holder for screwing	
Size	20 x 48 x 20 mm
Poster frame	DIN A3 – A6
Colour	Transparent (Polycarbonate)
Application	For attaching frames to walls or shelves.
	20 pieces
Item-No.	30002989



Frame holder for adhesive mounting	
Size	20 x 48 x 20 mm
Poster frame	DIN A3 – A6
Colour	Transparent (Polycarbonate)
Application	For attaching frames to walls or shelves.
VE	20 pieces
Item-No.	30002990



Box clamp	
Size	Adjustable up to max. 20 mm material thickness
Poster frame	DIN A3 – A6
Colour	Transparent (Polycarbonate)
Application	Adjustable clamp for universal attachment of all types of frames to crates and crates (wood/plastic).
VE	20 pieces
Item-No.	30002991



Box clamp	
Size	Adjustable up to max. 20 mm material thickness
Poster frame	DIN A1 – A2
Colour	Transparent (Polycarbonate)
Application	Adjustable clamp for universal attachment of all types of frames to crates and crates (wood/plastic).
VE	20 pieces
Item-No.	30002992



Double clamp for square suspension	
Size	35 x 20 x 9 mm
Poster frame	DIN A3 – A5
Colour	Transparent (Polycarbonate)
Application	Mounting clip for connecting poster frames at a 90° angle, with hole for hanging.
VE	20 piece
Item-No.	30004434

— Accessories: Frames



Frame magnet	
Size	36 x 32 mm
Poster frame	DIN A3 – A6
Load capacity	5,6 kg
Application	For attaching smaller frames to metal surfaces. Square, 90° to frame with 2 magnetic cores.
VE	20 pieces
Item-No.	30002993



Frame magnet	
Size	36 x 32 mm
Poster frame	DIN A1 – A2
Load capacity	5,6 kg
Application	For attaching smaller frames to metal surfaces. Square, 90° to frame with 2 magnetic cores.
VE	20 pieces
Item-No.	30002994



Frame connection	
Size	31 x 15 x 16 mm
Poster frame	DIN A3 – A6
Colour	Transparent (Polycarbonate)
Application	Consisting of two assembled parts for connecting several frames vertically or horizontally.
VE	20 pieces
Item-No.	30002995



Frame connection	
Size	31 x 15 x 16 mm
Poster frame	DIN A1 – A2
Colour	Transparent (Polycarbonate)
Application	Consisting of two assembled parts for connecting several frames vertically or horizontally.
VE	20 pieces
Item-No.	30002996



Film hinge for triangular and square suspension	
Size	50 x 27 x 19 mm
Poster frame	DIN A1 – A2
Colour	Transparent (Polycarbonate)
Application	Fastening clip for connecting several poster frames to form a triangular and square suspension.
VE	20 pieces
Item-No.	30004435

— Accessories: Frames



Pipe Hook	
Size	35 x 62 x 20 mm
Material	Polycarbonate
Poster frame	DIN A3 – A6
Application	Holder with movable hook for hanging single frames single frames on pipes with a Ø of up to 28 mm.
VE	20 pieces
Item-No.	30001608

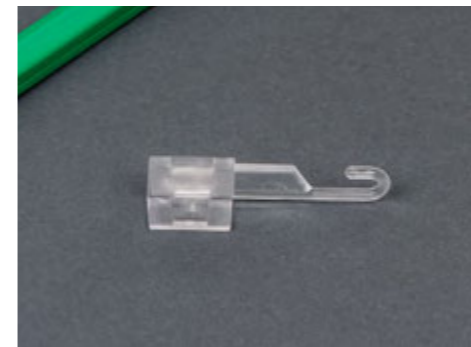

Hook, fix	
Size	15 x 16 mm and hook 57 mm
Material	Polycarbonate
Poster frame	DIN A3 – A6
Application	Clip with fixed hook for hanging single frames.
VE	20 pieces
Item-No.	30001609

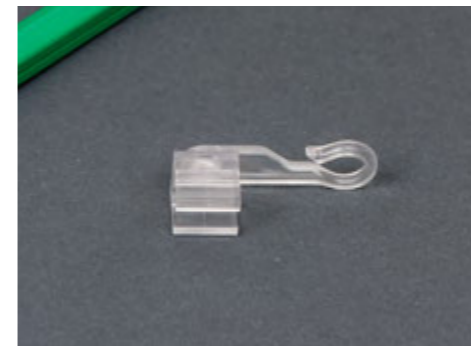

Hook, flexible	
Size	15 x 16 mm and hook 45 mm
Material	Polycarbonate
Poster frame	DIN A3 – A6
Application	Clip with movable hook for hanging individual frames, particularly suitable for baskets or similar.
VE	20 pieces
Item-No.	30001610



Hook top, fixed	
Size	16 x 14 x 39 mm
Material	Polycarbonate
Poster frame	DIN A3 – A6
Application	Mounting clip for frame.
VE	20 pieces
Item-No.	30001611



Hook top, fixed	
Size	16 x 14 x 39 mm
Material	Polycarbonate
Poster frame	DIN A3 – A6
Application	Side mounting clip for frame.
VE	20 pieces
Item-No.	30004497

— Accessories: Frames

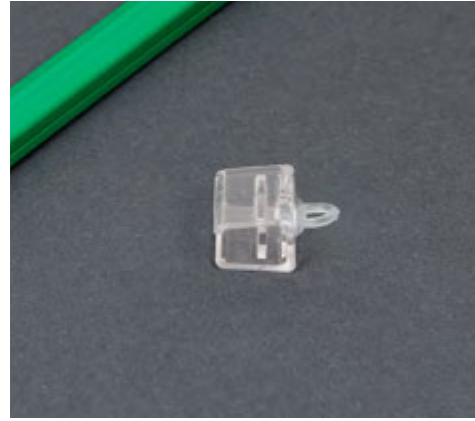

Eyelet, rotatable	
Size	28 x 15 x 16 mm
Poster frame	DIN A3 – A6
Colour	Transparent (Polycarbonate)
Application	Clip with rotating eyelet for hanging single frames or vertical frame combinations.
VE	20 pieces
Item-No.	30001605



Eyelet, rotatable	
Size	28 x 17 x 20 mm
Poster frame	DIN A1 – A2
Colour	Transparent (Polycarbonate)
Application	Clip with rotating eyelet for hanging single frames or vertical frame combinations.
VE	20 pieces
Item-No.	30003004



Pipe mount, big	
Size	48 x 32 x 16 mm
Poster frame	DIN A1 – A2
Pipe diameter	Ø 28 – 35 mm
Application	For attaching frames to pipes.
VE	20 pieces
Item-No.	30002986



Pipe mount, big	
Size	48 x 32 x 16 mm
Poster frame	DIN A3 – A6
Pipe diameter	Ø 28 – 35 mm
Application	For attaching frames to pipes.
VE	20 pieces
Item-No.	30001616

— Accessories: Frames



Ceiling mounted spider	
Length	75 mm
Stärke	1,5 mm
Colour	Silver
Material	Metal, stainless
Application	For fixing to grid ceilings (Odenwald ceilings).
VE	20 pieces
Item-No.	30002997



Ceiling magnet	
Load capacity	up to 2,8 kg
Size	44 x 12 mm, Eyelet Ø: 8 mm
Colour	Transparent/grey
Application	Clip with swivelling eyelet for hanging single frames or vertical frame combinations.
VE	20 pieces
Item-No.	30001613



S-Hook	
Colour	Grey
Material	Stainless steel
Application	Universal connector for connecting two elements or attaching to a chain.
VE	20 pieces
Size	20 mm
Item-No.	30001615



S-Hook	
Colour	Grey
Material	Stainless steel
Application	Universal connector for connecting two elements or attaching to a chain.
VE	20 pieces
Size	28 mm
Item-No.	30001616

— Accessories: Frames

C-Hook	
Size	39 mm
Material	Stainless steel
Colour	Silver
Application	Universal connector for connecting two elements or attaching to a chain.
VE	20 pieces
Item-No.	30002999



Pipe hook	
Size	70 mm
Material	Stainless steel
Colour	Silver
Application	For attaching to pipes with a maximum diameter of 35 mm or hanging on a chain.
VE	20 pieces
Item-No.	30001618



Hanger clamp	
Size	54 x 28 mm, 1,8 mm Shaped from strong wire
Material	Stainless steel
Colour	Silver
Application	For attachment to tubes with a diameter of max. 35 mm or hanging on a chain.
VE	100 pieces
Item-No.	30002830



Chain	
Length	25 m
Description	Deco chain V12
Material	Steel, nickel-plated, stainless
Colour	Silver
Application	Chain for suspending rails, posters, price displays, frames, etc. from the ceiling.
VE	1 piece
Item-No.	30001614



— List holder



Wall mount

- Robust and durable wall holder made of powder-coated sheet steel
- Capacity for 10 DIN A4 display boards
- Practical peg mechanism for easy replacement of display boards
- Easy to assemble
- Multiple wall mounts can be arranged in a row
- Measurements: 73 x 322 mm
- Colour: grey

VE = 1 piece
Item-No. 10002171



Display boards

- Polypropylene display panels for the wall mount
- Size DIN A4 – paper insertion from the top
- Low-reflection, scanner-compatible film
- Full wrap-around coloured profile frame

VE = 10 pieces

Item-No.	Colour
10002180	black
10002181	red
10002182	yellow
10002183	green
10002184	blue-violet
10002185	orange
10002186	grey
10002187	graphite
10002188	dark-blue
10002189	sorted by colour



Customized signage with vinyl lamination

Individual design: custom-made designs to match your corporate identity.
 Choose from a variety of high-quality materials such as acrylic or metal to represent your brand in the best possible way, whether for indoor or outdoor use, we create durable signage that can be used in a variety of ways as directional signs, door signs or company signs. Our experienced team also ensures professional installation directly on site so that your signage is not only visually appealing, but also functional.

Features

- High-quality vinyl foils:
- Printed or as a cut plot
- A wide variety of substrates:
 - e.g. aluminum composite, metal, acrylic glass, etc.
- For indoor and outdoor use
- UV and weather resistant
- Scratch and impact resistant
- Easy care

Service process:

- Customers contact us to discuss their detailed request. Based on the consultation, we create an individual concept and plan the best materials and sizes for your signage.
- After approval, the signage is manufactured to the highest quality and precision – using modern production techniques and durable materials.
- The finished signs are delivered on time and, if required, can be installed safely and precisely in the desired location by our specialist staff.

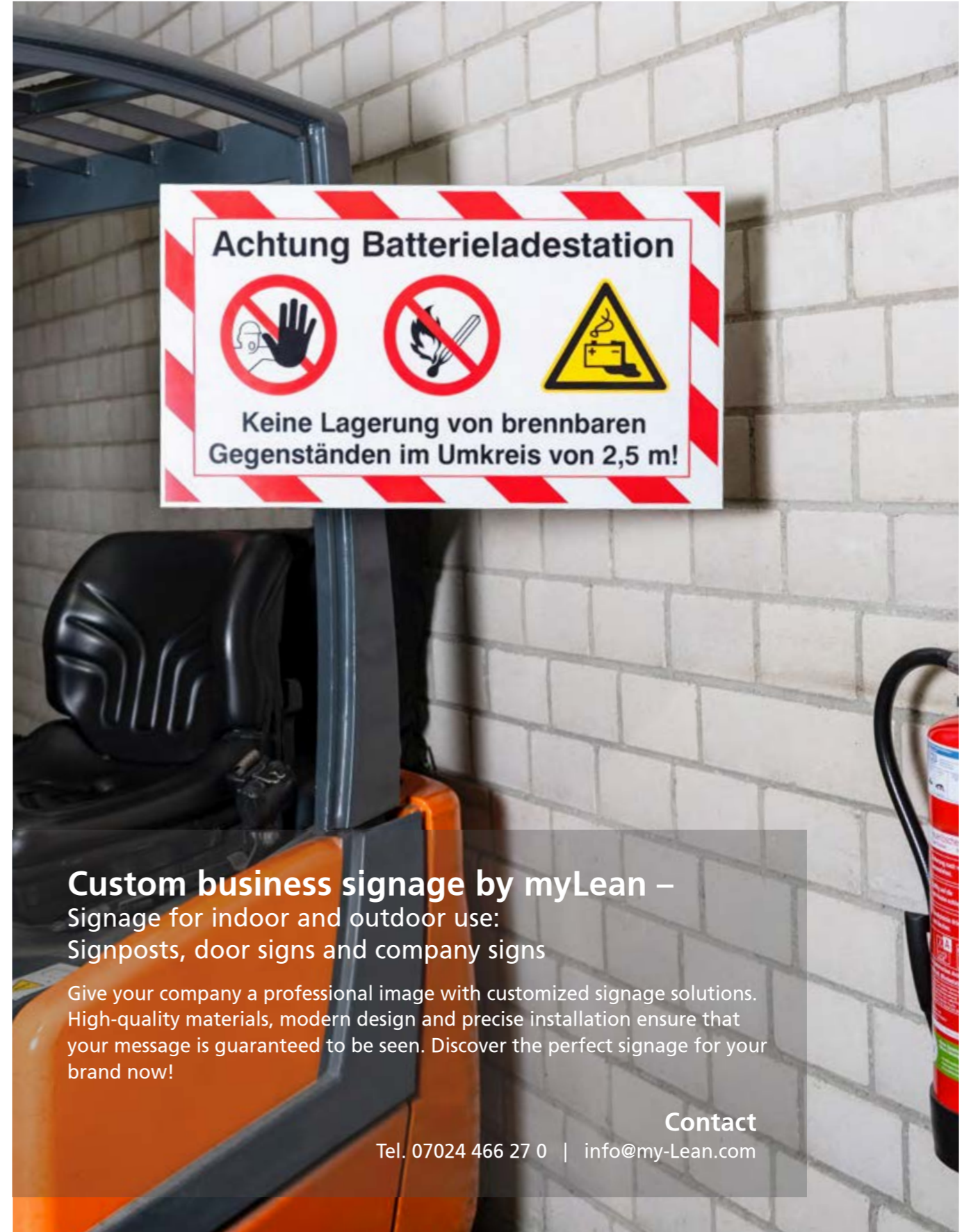

Custom business signage by myLean – Signage for indoor and outdoor use: Signposts, door signs and company signs

Give your company a professional image with customized signage solutions. High-quality materials, modern design and precise installation ensure that your message is guaranteed to be seen. Discover the perfect signage for your brand now!

Contact

Tel. 07024 466 27 0 | info@my-Lean.com

- 104 – 105 Visible pockets to attach
- 106 Visible pockets with magnetic tape
- 107 Visible pockets with neodymium magnet
- 108 KANBAN Visible pockets
- 110 General warehouse labelling
- 111 C-Profiles
- 112 – 114 Transparent magnetic labels
- 115 – 117 Magnetic tape

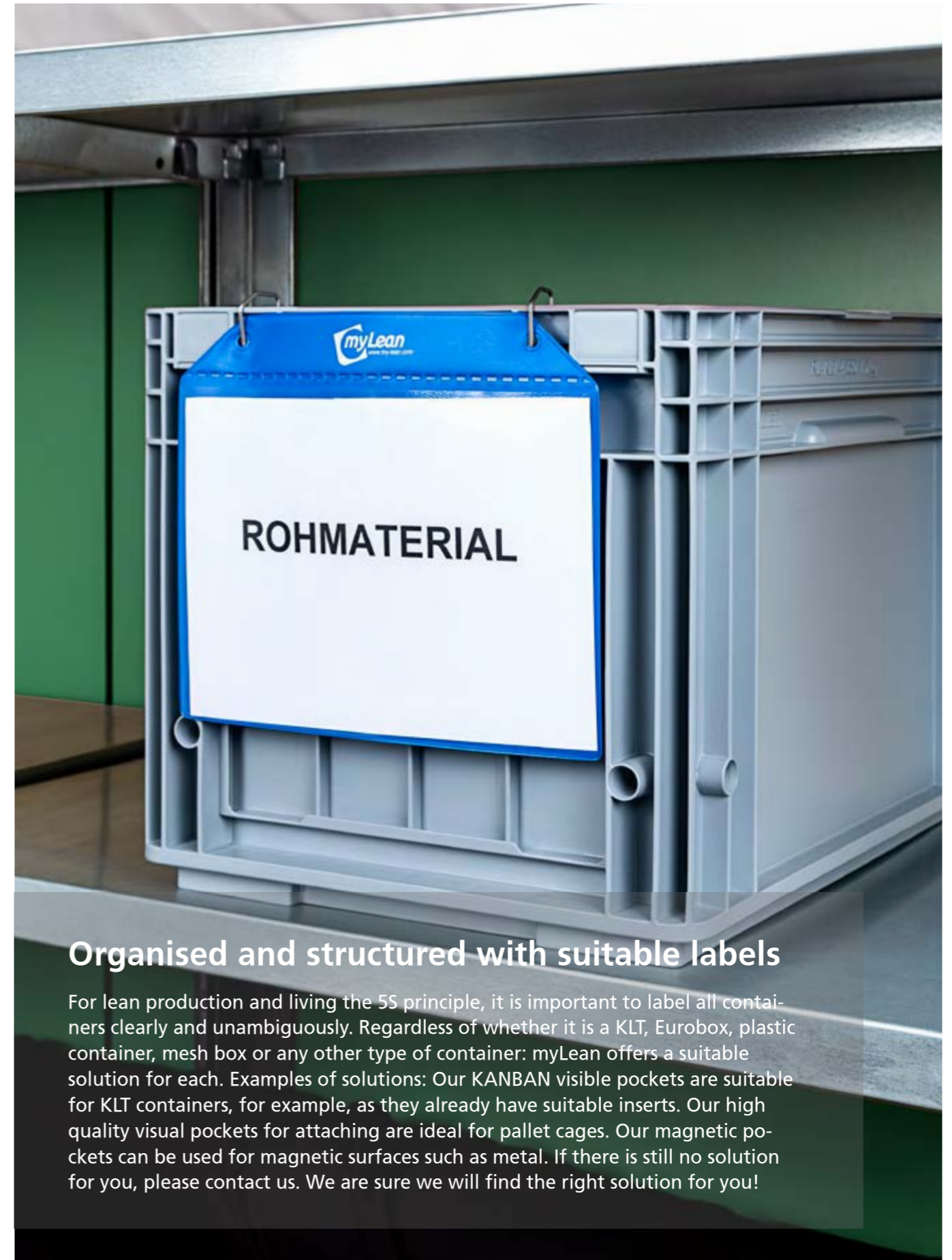

Organised and structured with suitable labels

For lean production and living the 5S principle, it is important to label all containers clearly and unambiguously. Regardless of whether it is a KLT, Eurobox, plastic container, mesh box or any other type of container: myLean offers a suitable solution for each. Examples of solutions: Our KANBAN visible pockets are suitable for KLT containers, for example, as they already have suitable inserts. Our high quality visual pockets for attaching are ideal for pallet cages. Our magnetic pockets can be used for magnetic surfaces such as metal. If there is still no solution for you, please contact us. We are sure we will find the right solution for you!

— Visible pockets to attach



Visible pockets to attach

There is no suitable way to attach labels to many containers. This can be remedied with the clip-on visual bag. These are available in various DIN formats and colours and optionally with a rain flap.

VE = 10 pieces



Width x Height (mm) format	255 x 300 DIN A4 oversize	300 x 220 DIN A4 q	220 x 300 DIN A4	217 x 155 DIN A5 q	155 x 217 DIN A5	155 x 110 DIN A6 q	217 x 110 Format I	Colour
Item-No.	30002030	30002040	30002044	30002050	30002054	30002060	30002070	green
	30002031	30002041	30002045	30002051	30002055	30002061	30002071	red
	30002032	30002042	30002046	30002052	30002056	30002062	30002072	blue
	30002033	30002043	30002047	30002053	30002057	30002063	30002073	yellow
Item-No._RS								

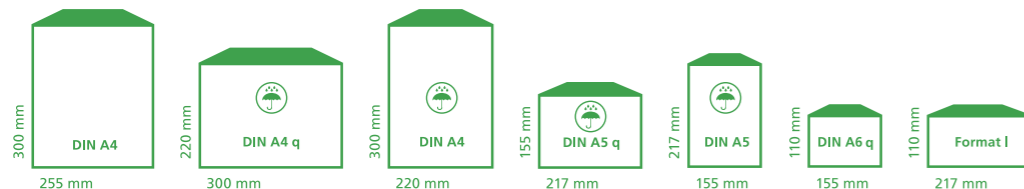

— Accessories for labels



Hook	
Measurements	170 x 65 x 21 mm
VE	10 pieces
Item-No.	30002913

Hook	
Measurements	240 x 40 mm
VE	20 pieces
Item-No.	30001621

S-Hook (20 mm)	
Measurements	90 x 120 x 60 mm
VE	20 pieces
Item-No.	30001615

S-Hook (28 mm)	
Measurements	90 x 120 x 60 mm
VE	20 pieces
Item-No.	30001616

C-Hook (40 mm)	
Measurements	90 x 120 x 60 mm
VE	20 pieces
Item-No.	30001617

Pipe hook (70 mm)	
Measurements	90 x 120 x 60 mm
VE	20 pieces
Item-No.	30001618

Chain (25 mm)	
Measurements	90 x 120 x 60 mm
VE	1 piece
Item-No.	30001614

Container labels

— Visible pockets with magnetic tape



Visible pockets with magnetic tape

For magnetic surfaces, you can obtain display pockets with magnetic tape from us. These are available in various DIN formats and colours and optionally with a rain flap.

VE = 10 pieces



Width x Height (mm) Paper format	255 x 300 DIN A4 oversize	300 x 220 DIN A4 q	220 x 300 DIN A4	217 x 155 DIN A5q	155 x 217 DIN A5	155 x 110 DIN A6q	217 x 110	110 x 110	Colour
Item-No.	30002080	30002090	30002100	30002110	30002120	30002130	30002140	30002150	green
	30002081	30002091	30002101	30002111	30002121	30002131	30002141	30002151	red
	30002082	30002092	30002102	30002112	30002122	30002132	30002142	30002152	blue
	30002083	30002093	30002103	30002113	30002123	30002133	30002143	30002153	yellow
Item-No._RS									

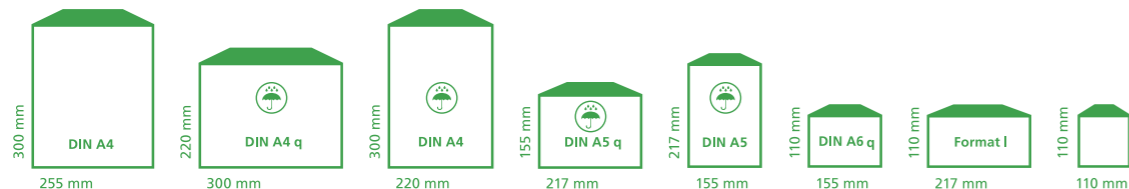

Container labels

— Visible pockets with neodymium magnet (extra strong)



Visible pockets with neodymium magnet

Where strong hold is needed, our display pockets with integrated neodymium magnets can help. Thanks to their high adhesive force and quality, they can also be used in windy places. These are available in various DIN formats and colours and optionally with a rain flap.

VE = 10 pieces



Width x Height (mm) Paper format	220 x 360 DIN A4 XXL	255 x 300 DIN A4 oversize	300 x 220 DIN A4 q	217 x 155 DIN A4	155 x 217 DIN A5 q	155 x 217 DIN A5	Colour
Item-No.	30002160	30002170	30002180	30002190	30002200	30002210	green
	30002161	30002171	30002181	30002191	30002201	30002211	red
	30002162	30002172	30002182	30002192	30002202	30002212	blue
	30002163	30002173	30002183	30002193	30002203	30002213	yellow
Item-No._RS							

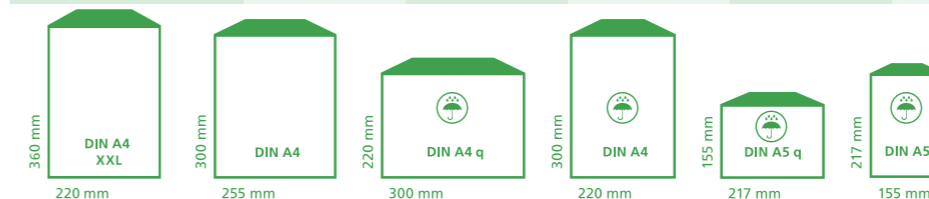



KANBAN visible pockets

The robust myLean KANBAN visible pockets are available in various colours and designs.

- Scanner-readable
- Suitable for all standard KLT containers and Euroboxes
- For insertion into KANBAN panels



Item-No.	Description according to VDA standard	Outer dimension	Inner dimension	Mounting	VE	Colour = x
30004035-x	open on the side	208 x 80 mm	200 x 67 mm	without	50	1 2 3 4 5 6 7
30004036-x	Magnetic open on the side	208 x 80 mm	200 x 75 mm	Magnetic strip on the back	50	1 2 3 4 5 6 7
30004037-x	self-adhesive open on the side	208 x 80 mm	200 x 75 mm	Self-adhesive strips on the back	50	1 2 3 4 5 6 7
30004038-x	Open top	208 x 80 mm	200 x 67 mm	without	50	1 2 3 4 5 6 7
30004039-x	Magnetic open top	208 x 80 mm	200 x 75 mm	Magnetic strip on the back	50	1 2 3 4 5 6 7
30004040-x	self-adhesive open at the top	208 x 80 mm	200 x 75 mm	Self-adhesive strips on the back	50	1 2 3 4 5 6 7



Always keep an overview with the warehouse labels from myLean

A well-organised and labelled warehouse is the be-all and end-all of lean production these days. myLean offers you magnetic warehouse labels in all designs, colours and sizes. By simply replacing the paper labels in the magnetic labels, you can decide for yourself how to label your goods and shelves quickly and easily. We are happy to offer you customised products on request.

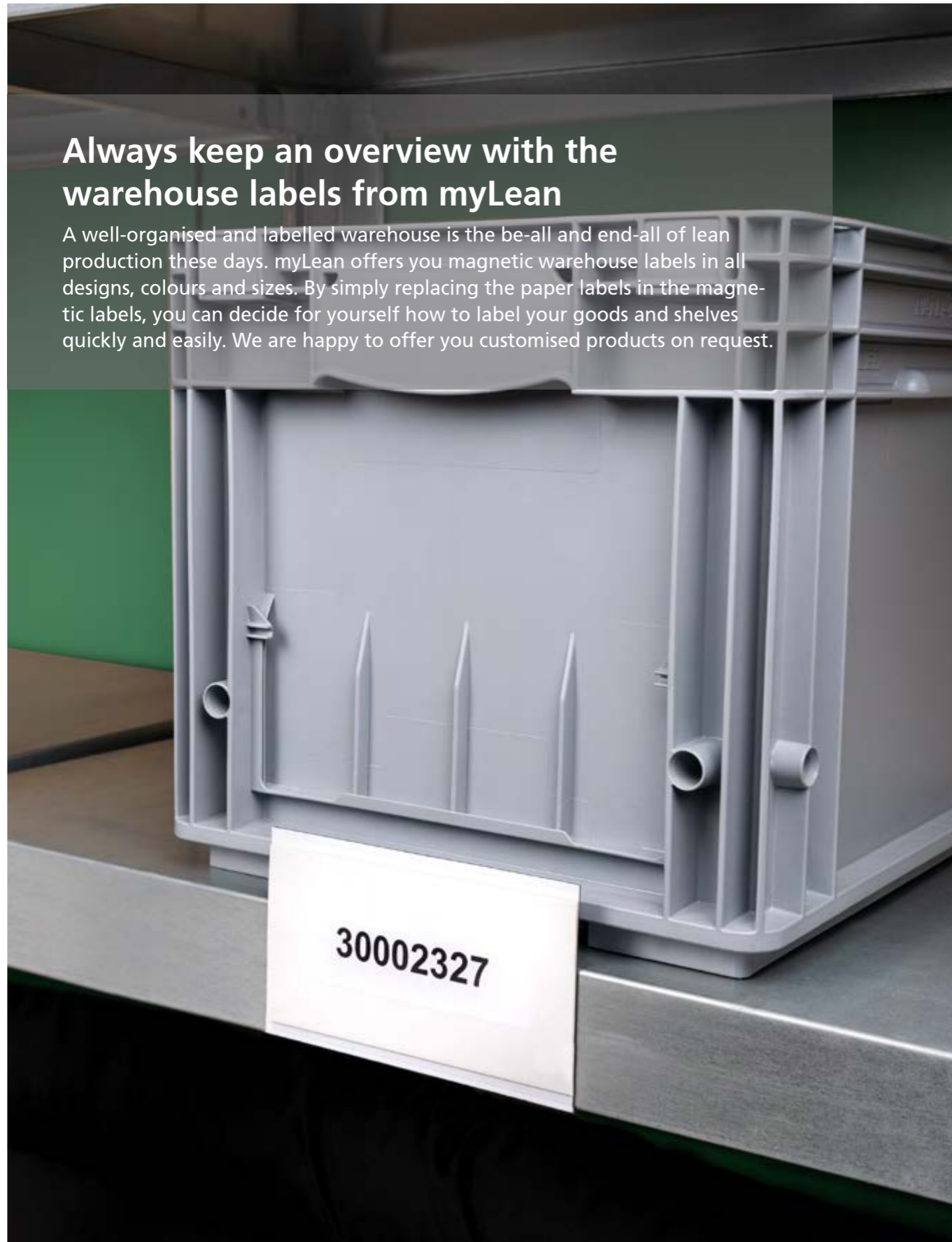

C-Profiles

The magnetic C-Profiles are ideal for warehouse labelling or as header and name strips on planning boards. You can use the magnetic C-Profiles to label your goods and the cards simply move with you when you move house. Thanks to the supplied labelling label and transparent cover, the label always stays clean and can be reused.

VE = 10 pieces



Item-No.	Width x Height in mm
30002300	40 x 15
30002301	50 x 15
30002302	60 x 15
30002303	40 x 20
30002304	50 x 20
30002305	60 x 20
30002306	70 x 20
30002307	50 x 25
30002308	60 x 25
30002309	70 x 25
30002310	80 x 25
30002311	60 x 30
30002312	70 x 30
30002313	80 x 30
30002314	100 x 30
30002315	80 x 40
30002316	90 x 40
30002317	100 x 40
30002318	120 x 40
30002319	80 x 50
30002320	100 x 50
30002321	120 x 50
30002322	150 x 50
30002323	100 x 60
30002324	120 x 60
30002325	150 x 60
30002326	180 x 60

Warehouse labels

— Transparent magnetic labels, open at the side



Transparent magnetic labels, open at the side

The transparent magnetic label including labelling board creates structure in your warehouse. Thanks to the full-surface magnetic back, it can be attached anywhere in the warehouse. The integrated transparent cover protects the labelling board from dirt and keeps the label clean. The outer width of the signs is approx. 6 cm more than the labelling area due to the welded joints.

VE = 10 pieces



Item-No.	Size of the labelling area Width x Height in mm
30002327	250 x 65
30002328	125 x 65
30002329	100 x 65
30002330	250 x 80
30002331	150 x 80
30002332	100 x 50
30002333	80 x 50

Warehouse labels

— Transparent magnetic labels, open at the side & top



Transparent magnetic labels, open at the side & top

This transparent magnetic sign is fully magnetic on the back. Ideally suited for quick and easy replacement of the labels, thanks to the opening at the side as well as at the top. The sign can be used again and again and is advantageous for changing labelling. Supplied without paper signs.

VE = 10 pieces



Item-No.	Size of the visible area Width x Height in mm
30002334	50 x 30
30002335	75 x 30
30002336	100 x 30
30002337	75 x 50
30002338	100 x 50
30002339	125 x 50

Pre-cut paper labels

Item-No.	Height in mm
30002340	30
30002341	50

— Transparent magnetic labels, open at the side & top



Transparent magnetic labels, open at the side & top

This transparent magnetic label is fully magnetic on the back. Ideally suited for quick and easy replacement of the signs, thanks to the opening at the side as well as at the top. A special highlight is the coloured marking strip at the top and bottom. This allows you to colour-code your goods. The sign can be used again and again and is advantageous for changing labelling. The overall width of the sign is sized by the 5 mm wide orientation strip. Supplied without paper labels.



VE = 10 pieces

Size of the visible area (mm)	50 x 30	75 x 30	100 x 30	75 x 50	100 x 50	125 x 50	Colours
Item-No.	30002342	30002346	30002350	30002354	30002358	30002362	yellow
	30002343	30002347	30002351	30002355	30002359	30002363	green
	30002344	30002348	30002352	30002356	30002360	30002364	blue
	30002345	30002349	30002353	30002357	30002361	30002365	red

Pre-cut paper labels

Item-No.	Height in mm
30002340	30
30002341	50

— Magnetic tape



Magnetic tape (10 m)

Determine the length of your warehouse labelling yourself and simply cut it to the required length from the roll using scissors. The magnetic tape rolls are also ideal for visual separation on shelves or boards. The blanks can be wiped clean with a damp cloth and re-labelled again and again.

VE = 1 roll a 10 meter



Width of roll (mm)	10	20	30	40	50	80	100	Colours
Item-No.	30002375	30002381	30002387	30002393	30002399	30002405	30002411	yellow
	30002376	30002382	30002388	30002394	30002400	30002406	30002412	green
	30002377	30002383	30002389	30002395	30002401	30002407	30002413	blue
	30002378	30002384	30002390	30002396	30002402	30002408	30002414	red
	30002379	30002385	30002391	30002397	30002403	30002409	30002415	white
	30002380	30002386	30002392	30002398	30002404	30002410	30002416	orange

— Magnetic tape: Perforated



Magnetic tape (perforated)

Thanks to the perforations, the magnetic labels can be easily and quickly removed from the roll by hand. The signs can be wiped clean with a damp cloth and labelled multiple times.



VE = 1 roll a 10 Meter

— Magnetic tape: Perforated



Size of sign (mm)	Signs/roll	yellow	green	blue	red	white	orange
80 x 10	1000	30002417	30002435	30002453	30002471	30002489	30002507
80 x 15	666	30002418	30002436	30002454	30002472	30002490	30002508
80 x 20	500	30002419	30002437	30002455	30002473	30002491	30002509
80 x 25	400	30002420	30002438	30002456	30002474	30002492	30002510
80 x 30	333	30002421	30002439	30002457	30002475	30002493	30002511
80 x 35	285	30002422	30002440	30002458	30002476	30002494	30002512
80 x 40	250	30002423	30002441	30002459	30002477	30002495	30002513
80 x 45	222	30002424	30002442	30002460	30002478	30002496	30002514
80 x 50	200	30002425	30002443	30002461	30002479	30002497	30002515
100 x 10	1000	30002426	30002444	30002462	30002480	30002498	30002516
100 x 15	666	30002427	30002445	30002463	30002481	30002499	30002517
100 x 20	500	30002428	30002446	30002464	30002482	30002500	30002518
100 x 25	400	30002429	30002447	30002465	30002483	30002501	30002519
100 x 30	333	30002430	30002448	30002466	30002484	30002502	30002520
100 x 35	285	30002431	30002449	30002467	30002485	30002503	30002521
100 x 40	250	30002432	30002450	30002468	30002486	30002504	30002522
100 x 45	222	30002433	30002451	30002469	30002487	30002505	30002523
100 x 50	200	30002434	30002452	30002470	30002488	30002506	30002524

- 120 General information
- 121 myLean magnet board customised
- 122 myLean whiteboard
- 123 myLean whiteboard customised
- 124 – 125 myLean LeanCube
- 126 – 135 Accessories



Organised planning & overview of your processes with myLean magnetic and whiteboards

Our magnetic and whiteboards help you every day with planning your assignments, important messages or as information boards. You can also use the board as a beamer or projector background. With the numerous accessories available, such as magnets or pens, you can display important information or processes visually and attractively.



Well visualised with myLean magnet boards

The myLean magnetic board consists of a white lacquered magnetic board and is edged with an aluminium profile. The (optional) four swivel castors with brakes make it easy and safe to move the magnetic board to the desired location in your company. Of course, the magnetic board is also available with adjustable feet.



Customised myLean magnet board

Easily design your own customised visual board using a combination of one or more individual boards. Our magnetic board is available with rolls, with adjustable feet or with a bracket for wall mounting.

The magnetic boards can be ordered in 3 different versions:

- with wall mount (W)
- with rack on rolls (R)
- with frame on adjustable feet (F)



Rack on rolls (R)



Rack on adjustable feet (F)

Z. B. 1245 mm x 250 mm in combination with 1245 x 350 mm

First select the size of your board:

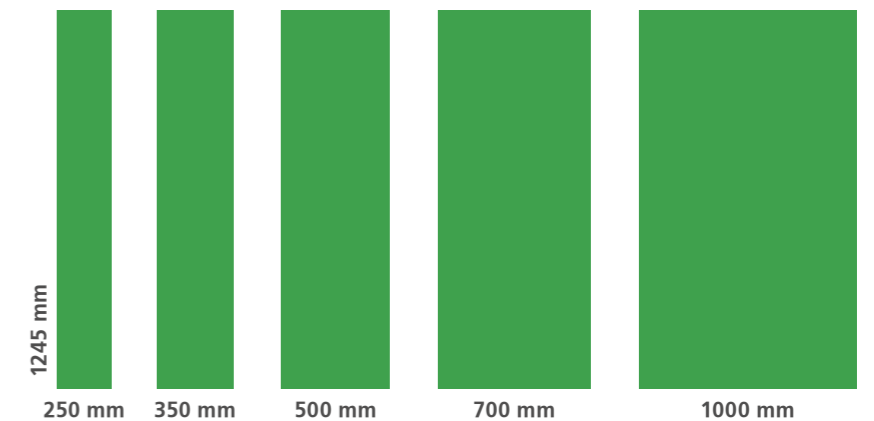

MB for magnetboard Total width: 950 mm Feet: F (Adjustable feet) | R (Castor feet) | W (Wall mount)

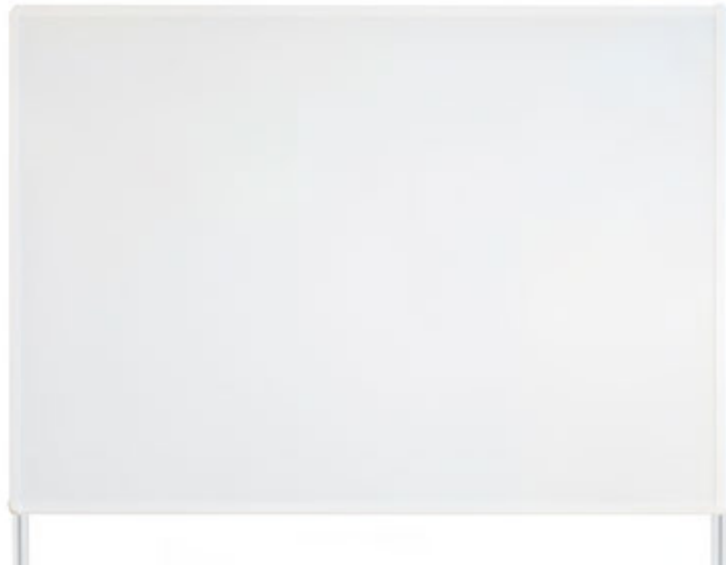

myLean whiteboard

The myLean whiteboard consists of a white, magnetic and writable surface and is surrounded by an aluminium frame. Our whiteboard is available with rolls, with adjustable feet or with brackets for wall mounting. By linking the individual whiteboards together, you can realise different set-up options.

The magnetic boards can be ordered in 3 different versions:

- with wall mount (W)
- with rack on rolls (R)
- with frame on adjustable feet (F)



Rack on rolls (R)

Rack on adjustable feet (F)

Board sizes in mm (B x H)	600 x 450	900 x 600	1200 x 900	2000 x 1000	Colours
Item-No.	30002659_W	30002662_W	30002665_W	30002668_W	white (RAL9002)
	30002660_R	30002663_R	30002666_R	30002669_R	
	30002661_F	30002664_F	30002667_F	30002670_F	
	30002671_W	30002674_W	30002677_W	30002680_W	Aluminium (anodised)
	30002672_R	30002675_R	30002678_R	30002681_R	
	30002673_F	30002676_F	30002679_F	30002682_F	



myLean whiteboard with 4-colour print

Design your customised whiteboard with your desired imprint for improved employee communication and illustration. This whiteboard is also magnetic and can be labelled. The aluminium frame is available in white or silver anodised, including mounting brackets for wall mounting and corner brackets. The print image in the background can be provided by you or customised by our agency.

Board sizes in mm (B x H)	600 x 400	900 x 600	1200 x 900	1200 x 1200	1500 x 1200	Colours
Item-No.	30002684	30002685	30002686	30002687	30002688	white
	30002689	30002690	30002691	30002692	30002693	Alu (anodised)

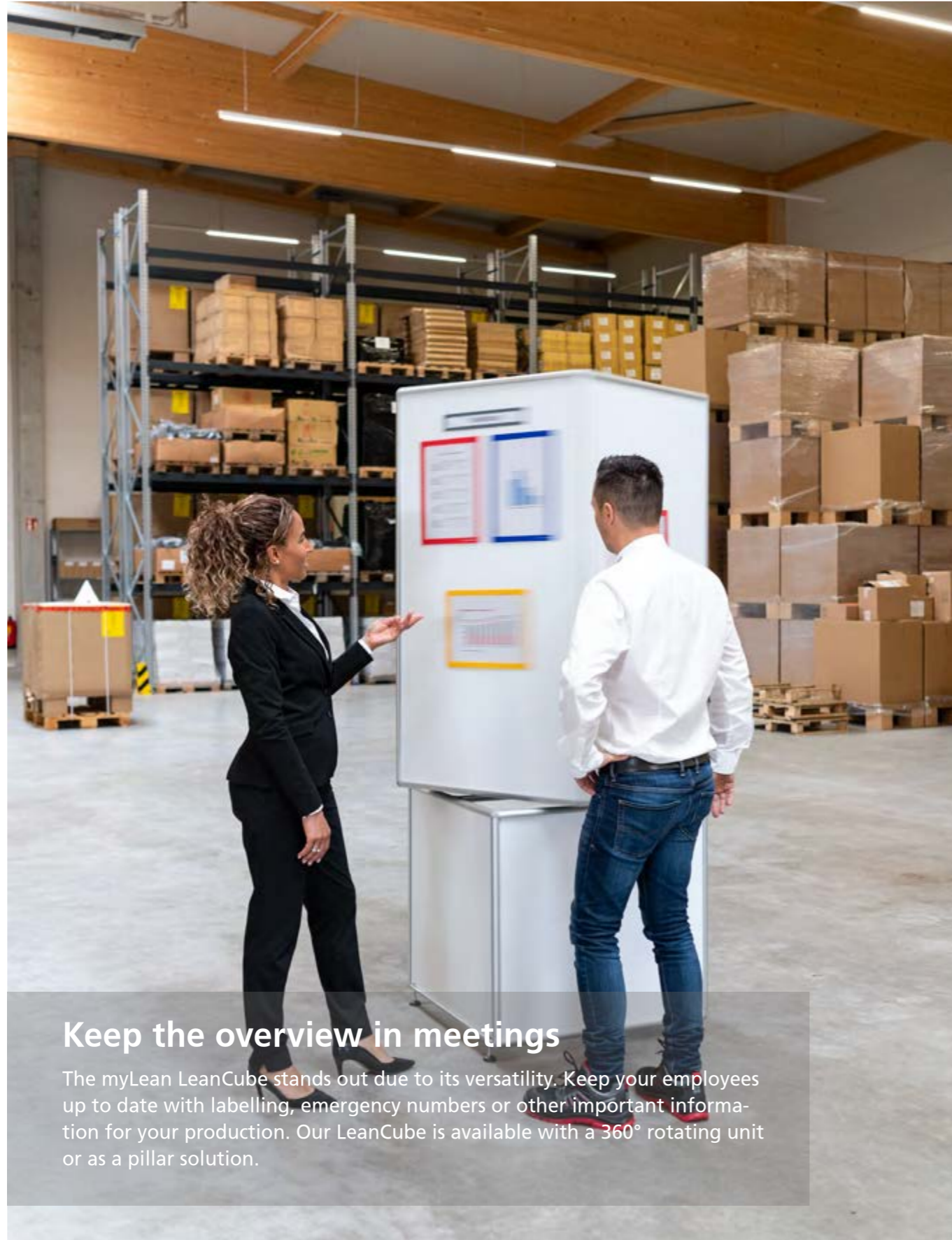

Keep the overview in meetings

The myLean LeanCube stands out due to its versatility. Keep your employees up to date with labelling, emergency numbers or other important information for your production. Our LeanCube is available with a 360° rotating unit or as a pillar solution.



myLean LeanCube

The surface of the myLeanCube is in whiteboard-quality and can also be written on with board markers.

The LeanCube can be ordered in 4 different versions can be ordered:

- with rack on rolls (R)
- with frame on adjustable feet (F)



Rack on rolls (R)



Rack on adjustable feet (F)

myLean LeanCube	rotatable 360° (F)	rotatable 360° (R)	not rotatable (F)	not rotatable (R)
Item-No.	10002325	10002387	10002326	10002327
Measurements	Height: 210 cm Width: 74 cm Low: 74 cm			



Starterkit for whiteboards	
Description	Consists of: <ul style="list-style-type: none"> • 4 pens (red, black, blue, green) • 1 magnetic pen holder • 10 round magnets • 1 dry wipe • 1 bottle of cleaning agent • 10 sheets of blotting paper
Item-No.	30002705



Magnetic pen holder	
Description	The white holder with magnetic tape ensures that your whiteboard pens are clearly organised.
Colour	white
VE	1 piece (without pens)
Item-No.	30002704



Pen clip	
Description	<ul style="list-style-type: none"> • made from plastic Ø ca. 40 mm • Clamping width: 5 – 15 mm • Self-adhesive back
Colours	black/black; black/red; black/yellow; black/green; black/blue
VE	10 pieces
Item-No.	30002967

Items may differ from illustrations



Magnetic ring binder

Are you fed up with the constant chaos of sheets on your shelves? - Then the magnetic ring binders are just right for you! If necessary, you can easily remove individual sheets and, thanks to the opening lever, you can do this with just one hand. Rubber magnetic feet ensure a secure and firm hold. These are gentle on surfaces and leave no marks when removed.

VE = 1 piece



Item-No.	Number of rings	Measurements (mm)
30002775	2 x Ø 35	155 x 55
30002776	4 x Ø 35	317 x 55
30002777	2 x Ø 45	115 x 50

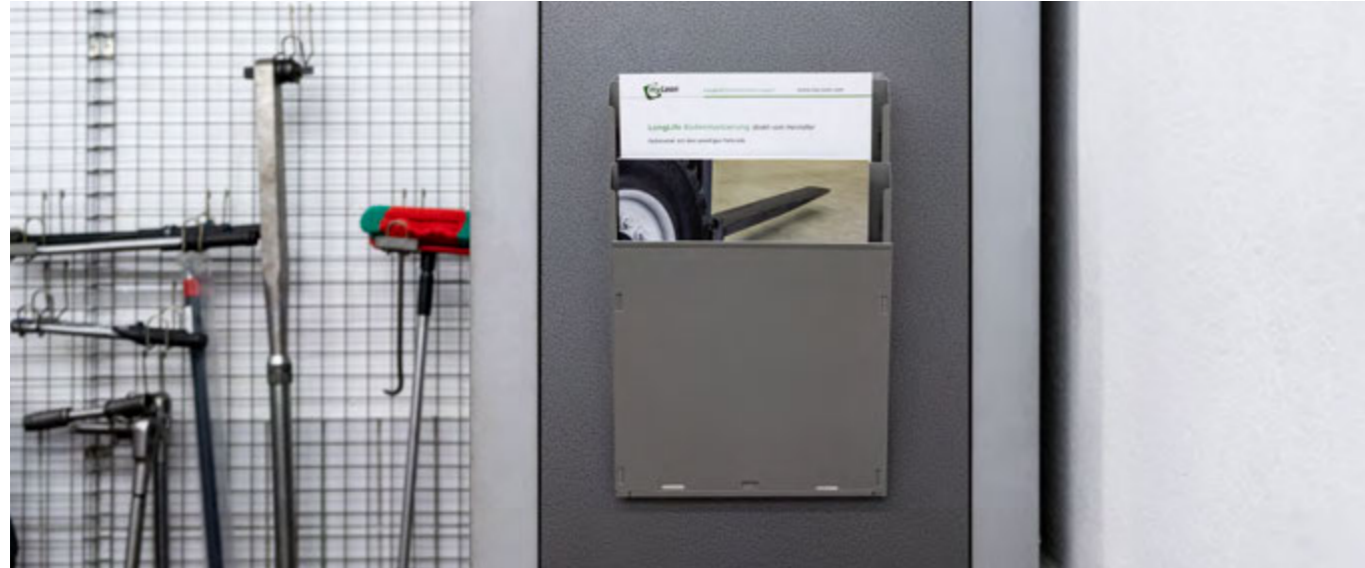

Slip-in shelves





With the myLean insert compartments you get an ideal storage system for all workstations in your company.

Consisting of a powder-coated end panel, two wall brackets and six or two compartments. The compartments can be extended as required, both in portrait format

DIN A4 portrait format and **DIN A4** landscape format and are available in available in 4 colours.

VE = 1 piece



Variant	6 compartments	2 compartments	Colours
Item-No.	30002763	30002767	 red
	30002764	30002768	 grey
	30002765	30002769	 blue
	30002766	30002770	 yellow



Slip-in shelves (magnetic)

Keep your standboard organised with the transparent insert compartments from myLean. You can insert leaflets, information sheets or documents, for example, and have them directly at eye level (depending on how they are mounted). Simply drill a hole in the desired position on your magnetic board or simply attach with the magnetic strips on the back and create a better overview for your employees.



Material: Polystyrol | Colour: transparent

Item-No.	Format	Attachment	Measurements (mm)
30004018	DIN A4	Magnetic strip on the back	245 x 228 x 36
30004019	DIN A5	Magnetic strip on the back	162 x 158 x 41
30004020	DIN A5 q	Magnetic strip on the back	122 x 217 x 41
30004021	DIN A4	Wall mounting	245 x 228 x 36
30004022	DIN A5	Wall mounting	162 x 158 x 41
30004023	DIN A5 q	Wall mounting	122 x 217 x 41



Magnetic viewing visible pockets

The magnetic viewing windows can be attached quickly and easily using the three-sided magnetic frame. The opening on one side allows you to easily change documents. The anti-reflective film protects your notices from dirt and damage. The window can be used in both portrait and landscape format.

VE = 5 pieces



Item-No. DIN A3	Item-No. DIN A4	Colour
30002694	30002699	red
30002695	30002700	green
30002696	30002701	blue
30002697	30002702	yellow
30002698	30002703	silver



Magnetic viewing visible pockets, writable

The labelling frames allow important documents, such as cleaning lists or maintenance schedules to be labelled directly. The magnetic strips on three sides on the back ensure strong adhesion and at the same time make it easy to change documents thanks to the one-sided opening. The magnetic frames are available in various colours and therefore help you to label different topics.

VE = 5 pieces



Item-No. DIN A3	Item-No. DIN A4	Colour
30004024	30004029	red
30004025	30004030	green
30004026	30004031	blue
30004027	30004032	yellow
30004028	30004033	silver



Magnetic headlines

The magnetic headings help you to structure your magnetic and whiteboards. The headings are also available in different colours and can therefore be perfectly combined with the magnetic frames.

VE = 5 pieces



Item-No. DIN A5 q/DIN A4	Item-No. DIN A4 q/DIN A3	Colour
30004008	30004013	red
30004009	30004014	green
30004010	30004015	blue
30004011	30004016	yellow
30004012	30004017	silver

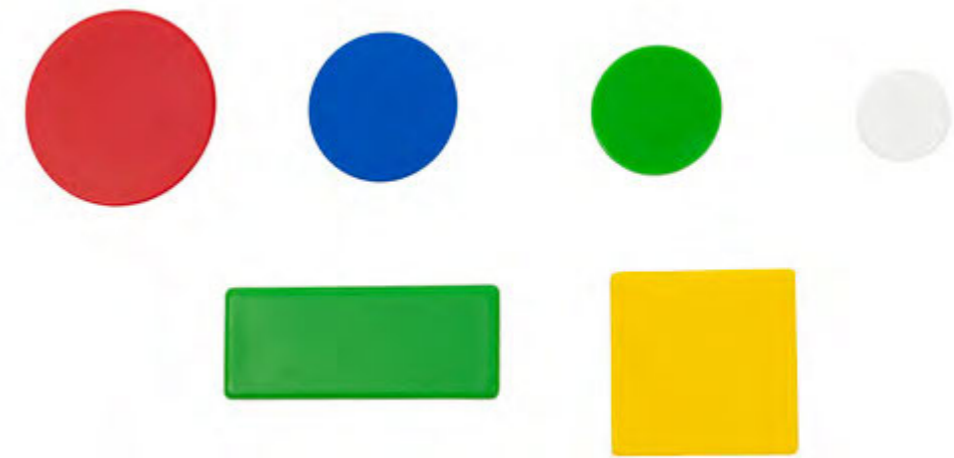

Organising magnets with neodymium magnet

The coloured organiser magnets with neodymium magnet are extremely adhesive – even with several documents. The grip edge prevents slipping.

VE = 20 pieces, each colour



Size	Ø 18 mm	Ø 25 mm	Ø 30 mm	Ø 40 mm	35 x 35 mm	55 x 22,5 mm	Colour
Item-No.	30002706	30002713	30002720	30002727	30002734	30002741	blue
	30002707	30002714	30002721	30002728	30002735	30002742	yellow
	30002708	30002715	30002722	30002729	30002736	30002743	green
	30002709	30002716	30002723	30002730	30002737	30002744	red
	30002710	30002717	30002724	30002731	30002738	30002745	white
	30002711	30002718	30002725	30002732	30002739	30002746	orange
	30002712	30002719	30002726	30002733	30002740	30002747	grey

Items may differ from illustrations



Organisation magnets

Coloured organisation magnets for your board with a grip edge to prevent slipping.

VE = 20 pieces



Size	Ø 25 mm	Ø 30 mm	Colour
Item-No.	30002748	30002755	blue
	30002749	30002756	yellow
	30002750	30002758	green
	30002751	30002759	red
	30002752	30002760	white
	30002753	30002761	orange
	30002754	30002762	grey

Items may differ from illustrations



Magnetic smileys

Use these smileys to provide clear information and create a friendlier and more pleasant working atmosphere. Visualise clear information with the smileys.

VE = 10 pieces, each colour



Item-No.	Holding magnet Ø 30 mm Magnetic foil Ø 40 mm	Mood	Colour
30002369	Holding magnet	happy	green
30002370	Holding magnet	neutral	yellow
30002371	Holding magnet	sad	red
30002372	Magnetic foil	happy	green
30002373	Magnetic foil	neutral	yellow
30002374	Magnetic foil	sad	red

Items may differ from illustrations

— Material flow solutions from one source

- 138 – 139 Supply trolley
- 140 – 141 Pallet trolley & pallet cover
- 142 – 143 FiFo-Material supply
 - 144 Parking rails
 - 145 Ground roller: Dolly 64
- 146 – 147 Crate lifters

— For an optimally organised supply chain



The right material – at the right time, in the right quantity – at the right place

The diversity of today's production processes requires a reliable supply of materials. Station systems and parking bays enable the targeted provision of rolling goods. Signage/labelling simplifies allocation and creates process reliability. Thanks to the simple assembly and freely expandable rails made of high-quality aluminium, the first-in, first-out principle can be implemented with certainty. Simply screw or glue the rails to the floor and easily extend your lane to your desired length using the connecting rail. We are happy to provide you with complete solutions for the provision of materials, including the rail system, aluminium profile construction and signage.



Supply trolley: 600 | 800 | 810

- Can be loaded and unloaded from both sides
- Base shelf and 3 intermediate shelves
- 2 fixed castors
- 2 swivel castors with brakes
- Elastic rubber tyres (Ø 160 mm)
- Push handle incl. deceleration aid
- Parking brake
- 4 insertion corners and overrun protection
- Galvanised (powder-coated on customer request)



Available with handbrake on request

Item-No.	Size Description	Load capacity	Speed	Train weight
30004054	Supply trolley 600 Dimensions: 1515 x 592 mm Usable area: 1215 x 572 mm	Base plate: 300 kg Intermediate plate: 150 kg max. load: 1000 kg	max. 6 km/h	max. 3000 kg
30004055	Supply trolley 800 Dimensions: 1515 x 820 mm Usable area: 1215 x 798 mm	Base plate: 300 kg Intermediate plate: 150 kg max. load: 1000 kg	max. 6 km/h	max. 3000 kg
30004056	Supply trolley 810 Dimensions: 1515 x 830 mm Usable area: 1215 x 808 mm	Base plate: 300 kg Intermediate plate: 150 kg max. load: 1000 kg	max. 6 km/h	max. 3000 kg
30004057	Clutch			
30004058	Drawbar			



Supply trolley Flexi

- Can be loaded and unloaded from both sides
- Solid base shelf with 2 hanging shelves (individually height-adjustable)
- 4 swivel castors (2 with brakes)
- 2 push handles
- High-quality powder-coated surface (RAL 9006)
- Additional shelves optional



Various wheels available on request

Features	
Item-No.	10002521
Weight	50 kg
Measurements	172 cm incl. rolls 80 cm x 60 cm
Accessories (inclusive)	2 pieces hanging shelves
Miscellaneous	2 Swivel castors 2 Fixed castors with brakes
Extension	30004323 (Additional hanging shelves)



Pallet trolley

- Can be loaded and unloaded from both sides
- 2 fixed castors made of extratjame (Ø 160 mm)
- 2 swivel castors made of polyamide (Ø 160 mm)
- Push handle
- 4 insertion corners and drive-over protection
- Powder-coated surface RAL 5010
- Removable push handle

Item-No.	Size Description	Load capacity	Speed	Pull weight
30004048	Industrial pallet Dimensions: 1390 x 1070 mm Usable area: 1225 x 1025 mm	max. 1000 kg	max. 6 km/h	max. 3000 kg
30004049	Half Euro pallet Dimensions: 990 x 670 mm Usable area: 825 x 625 mm	max. 1000 kg	max. 6 km/h	max. 3000 kg
30004050	Euro pallet Dimensions: 1390 x 870 mm Usable area: 1225 x 825 mm	max. 1000 kg	max. 6 km/h	max. 3000 kg
30004051	Industrial pallet attachment	1000 kg		
30004052	Top half Euro pallet	1000 kg		
30004053	Euro pallet attachment	1000 kg		
30004057	Clutch			
30004058	Drawbar			



Pallet cover

The safest, easiest and most cost-effective way to secure your load on a pallet. No wrapping or stretch film required, which also protects the environment. This time saving significantly reduces your labour costs.



Item-No.	Measurements (L x B x H)	Weight	Material	Max. Stacking load
30004324	Euro pallet cover 1210 x 810 x 100 mm	with 2 straps: 8 kg	High-impact polypropylene	2000 kg
30004325	Half Euro pallet cover 822 x 618 x 93 mm	with 2 straps: 6,15 kg	High-impact polypropylene	2000 kg



FiFo-Material supply

Our FiFo rails are ideal for your material provisioning as well as for buffering and storing your products. The rail system is available in two different track widths (41 mm or 52 mm).

VE = 1 piece



Item-No.	Track length in mm for 41 mm rolls
30002588	1200
30002589	1800
30002590	2400

Item-No.	Track length in mm for 52 mm rolls
30002591	1200
30002592	1800
30002593	2400



Item-No.	Brake for tracks
30002602	Track width 41 + 52, plastic



Item-No.	Connecting rail (VE = 1 piece)
30002601	Track width 40/Track width 52

Item-No.	Connecting and positioning element in mm (VE = 2 pieces)
30002594	400
30002623	600
30002595	800

Item-No.	End pieces (VE = 2 pieces)
30002597	Track width 41, plastic
30002599	Track width 52, plastic
30002598	Track width 41, steel
30002600	Track width 52, steel
30004305	Track width 41, spread
30004255	Track width 52, spread

Item-No.	Dowel plate (VE = 2 pieces)
30002792	Steel (with fixing kit, without dowels for floor anchoring)

Item-No.	Limit stop
10002178	Steel SW 41
10002179	Steel SW 52

Item-No.	Slot cover
30004003	2000 mm – black



Parking rails

Safe parking with the myLean parking rail. Use the myLean parking rail to position your floor rollers and pallet trolleys. The parking rail made of high-quality aluminium allows you to fill or empty the container easily and safely without it rolling away. Simply stick the rail to the floor at any point.



Item-No.	Parking rail high-high (12/12 mm) in mm incl. 4 end pieces
30002605	400
30002606	800
30002607	1200
30002608	2400



Item-No.	Parking rail low-low (6/6 mm) in mm incl. 4 end pieces
30002613	400
30002614	800
30002615	1200
30002616	2400



Item-No.	Parking rail low-high (6/12 mm) in mm incl. 4 end pieces
30002609	400
30002610	800
30002611	1200
30002612	2400



Ground roller Dolly 64 – 300

The trolley has a load capacity of 300 kg and can be linked together using the innovative uni-Link function. When stacked on top of each other, they can be stowed away to save space. Depending on requirements, it can be fitted with different wheels and other accessories.

- Floor trolley with uni-Link
- Castors with parking brake
- Fast cross-stacking
- 4x abrasion-resistant swivel castors



Item-No.	Measurements (L x B x H)	Rolls	Material	Max. Load
30004322	600 x 400 x 173,5 mm	4 Swivel castors Material: Galvanised steel Roller diameter: 100 mm	High impact-resistant polypropylene	300 kg



The simple and ergonomic provision of your work materials

Simple and ergonomic provision of your work materials at the desired height with the myLean crate lifting device. Both electric and pneumatic versions are available. Invest in a back-friendly and practical device – your employees will thank you with more effective work performance!

Crate lifters

The electric lifting device is equipped with a control panel with an emergency stop button or sensory height detection/light sensor (optional), schuko-plug and CE labelling. The surface is powder-coated or galvanised. Sturdy castors and handles are available on request for safe manoeuvring. Alternatively, the pneumatic version can be operated using a hand lever.

All versions are also available at 6 bar or 230 V.

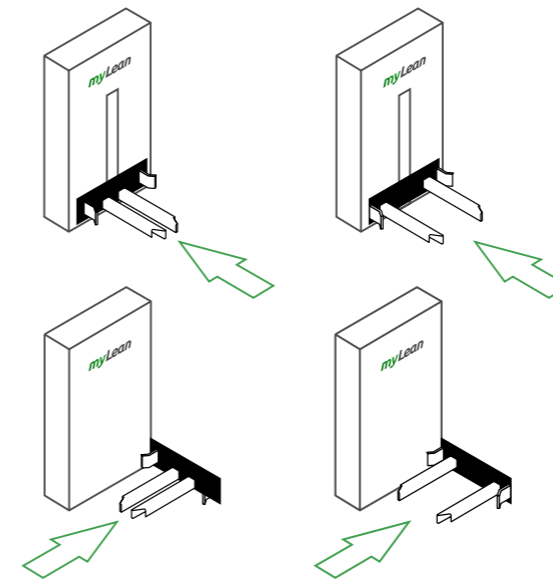

Item-No.	Crate lifter	Lifting height in mm	Load capacity in kg
40001003	Front longitudinal loading	720 – 920	200 – 500
40001004	Front transverse loading	720 – 920	200 – 500
40001005	Lateral longitudinal loading	720 – 920	200 – 400
40001006	Lateral transverse loading	720 – 920	200 – 400
40001007	Double – loading sideways lengthwise	720 – 920	200
40001008	Tandem – loading sideways lengthwise	720 – 920	200 – 300
40001009	Tandem – lateral transverse loading	720 – 920	200 – 300

— Products with profiles

150 General information

151 Customised profile solutions

— Profile solutions with a system – customised for you



Profile construction from experts

Design and determine your individual, ergonomic and flexible workstation systems or profile products. Whether workstations for material workstations or profile weighing systems, myLean makes your ideas come true. Production is completely customised to your wishes and requirements. Trained personnel and our expertise make the myLean profile products a price-performance hit.



We produce the perfect profile construction for you!

In our profile workshop, we use the profile construction kits established on the market to produce customised profile construction solutions. Benefit from our universal approach and our many years of experience in profile construction.



From the idea to customised product solutions

Our range of services includes consulting and planning, supported by our CAD department, as well as the realisation of the profile solution.

Please contact us for your individual aluminium profile system.



Imprint

Publisher

myLean GmbH
Rechbergstraße 7 | 73770 Denkendorf

Phone: +49 7024 466 27 – 0

Fax: +49 7024 466 27 – 10

info@my-lean.com

www.my-lean.com

Copyright

myLean GmbH

Text rights

myLean GmbH

Image copyrights

Seite 2: Sergey Petinov (123rf.com)

Place of publication

Denkendorf

Year

2024

1. Edition

Subject to technical changes, errors and misprints. Illustrations similar.



myLean

Lean products from the producer

myLean® Order-Hotline
Mo. – Do. 7:30 Uhr – 16:30 Uhr
Fr. 7:30 Uhr – 15:30 Uhr

Phone 07024 / 466 27 0

myLean GmbH
Rechbergstraße 7
73770 Denkendorf

Phone +49 7024 466 27 – 0
Fax +49 7024 466 27 – 10

info@my-Lean.com

www.my-Lean.com